

Tenant Improvement for:
Building B, Bay 10
SOUTHERN PARK OF COMMERCE
Palm Beach County, Florida

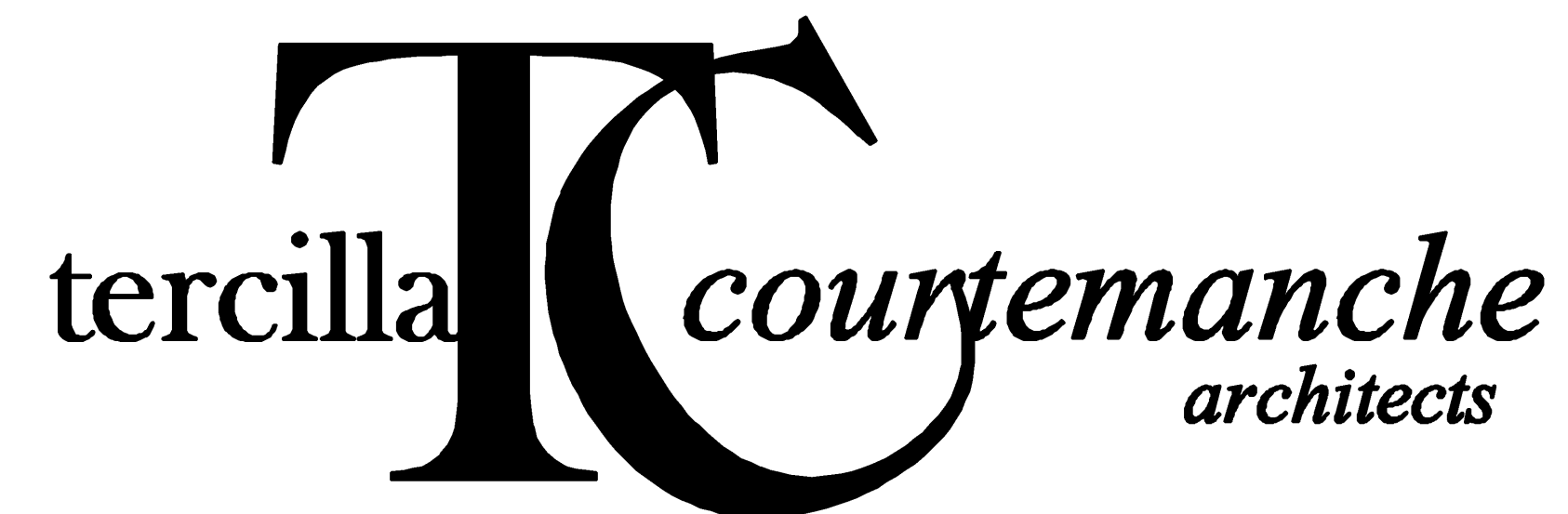

AA 0003414

TO THE BEST OF MY KNOWLEDGE,
THESE DRAWINGS ARE COMPLETE AND
COMPLY WITH THE FLORIDA BUILDING CODE, THE FLORIDA
FIRE PREVENTION CODE AND ALL OTHER APPLICABLE
CODES AND REGULATIONS.

ARCHITECT:

TERCILLA COURTEMANCHE
architects, inc.

2047 Vista Parkway, Suite 100
West Palm Beach, Florida 33411
Tel. 561-478-4457, Fax 561-478-4102

MECHANICAL / ELECTRICAL / PLUMBING:

CHANE, INC.

2705 Park Street
Lake Worth, Florida 33460
Tel. 561-586-4003, Fax 561-586-5688

SHEET INDEX

ARCHITECTURAL

COVER SHEET

- A1.1 FLOOR PLAN, MEZZANINE PLAN, CEILING PLANS & SCHEDULES
A2.1 DETAILS & WALL TYPES

MECHANICAL / ELECTRICAL/ PLUMBING

- M1.1 PLUMBING & HVAC PLANS, SCHEDULES, NOTES & DETAILS
E1.1 ELECTRICAL PLAN, SCHEDULES, NOTES & DETAILS

| FINISH SCHEDULE | | | | | | | |
|-----------------|-------------|----------|----------|----------------|---------|--------------|---|
| ROOM # | ROOM NAME | FLOOR | BASE | WALLS | CEILING | CLNG. HGT. | REMARKS |
| 100 | WAREHOUSE | CONCRETE | 4" VINYL | CONC./G.W.B. | EXPOSED | - | VINYL BASE @ GWS LOCATIONS ONLY. |
| 101 | R/LJ/SHOWER | TILE | TILE | PAINTED G.W.B. | G.W.B. | 8'-0" A.F.F. | EPOXY PAINT, FULL HEIGHT TILE @ SHOWER WALLS. |
| 102 | R/LJ/SHOWER | TILE | TILE | PAINTED G.W.B. | G.W.B. | 8'-0" A.F.F. | EPOXY PAINT, FULL HEIGHT TILE @ SHOWER WALLS. |
| 200 | WAREHOUSE | CONCRETE | 4" VINYL | CONC./G.W.B. | EXPOSED | - | VINYL BASE @ GWS LOCATIONS ONLY. |
| 201 | OFFICE | CARPET | 4" VINYL | PAINTED G.W.B. | 2X4 ACT | 8'-0" A.F.F. | |

FINISH SCHEDULE NOTES:

1. CONFIRM ALL FINISH MATERIALS WITH TENANT PRIOR TO CONSTRUCTION, INCLUDING BUT NOT LIMITED TO WALLCOVERINGS, FLOORING, WALL BASE, CABINETRY, ETC.
2. PAINT TO BE APPLIED AS FOLLOWS: ONE (1) COAT OF PRIMER AND TWO (2) COATS OF FINISH PAINT.
3. CONTRACTOR TO PROVIDE TRANSITION STRIPS AT THE CENTER OF DOOR OPENINGS WHERE OFFERING FLOORING MATERIALS MEET.
4. OFFICE PAINT TO BE 448-5 "BLIVER BLUEBERRY" BY PORTER PAINT. OFFICE CARPET TO BE 3088 "ENERGIZE" BY SHAW.
5. RESTROOM PAINT TO BE 301-4 "JERICO JADE" BY PORTER PAINT. RESTROOM FLOOR AND SHOWER WALL TILE TO BE "ASPEX" 1626 SIERRA GLAZED BY DAL TILE.
6. TENANT TO ACID STAIN GROUND FLOOR AQUA BLUE BY COLONIAL FLOORING.

THE FOLLOWING WORK TO BE COMPLETED BY CONTRACTOR AND PAID FOR BY TENANT:

1. PAINT EXIST. CONCRETE WAREHOUSE WALLS W/ 231-7 "RUM PUNCH" BY PORTER PAINT. PAINT WAREHOUSE G.W.B. W/ 345-8 "BERMUDA" BY PORTER PAINT.
2. PAINT ALL METAL INCLUDING STAIRS, JOISTS, METAL DECK AND BACK DOOR W/ HIGH GLOSS BLACK PAINT.

| DOOR SCHEDULE | | | | | | |
|----------------|-------------|------------|-----------------|--|--------------|--|
| OPENING NUMBER | DOOR | | FRAME | | REMARKS | |
| | SIZE | MATL. TYPE | MATL. HWDR | | | |
| 1 | 3'-0"x7'-0" | WOOD A | WD. PRIVACY SET | | | |
| 2 | 3'-0"x7'-0" | WOOD A | WD. PRIVACY SET | | | |
| 3 | 3'-0"x7'-0" | WOOD A | WD. PASSAGE SET | | | |
| 4 | 3'-0"x7'-0" | WOOD B | - | | BI-FOLD DOOR | |
| E | EXISTING | - | - | | | |

DOOR HARDWARE SETS:

1. DOOR HARDWARE TO BE LEVER ACTION SCHLAGE "AL" SERIES JUPITER, 820 FINISH.
2. CONTRACTOR TO VERIFY ALL DOOR HARDWARE REQUIREMENTS W/ TENANT PRIOR TO INSTALLATION.

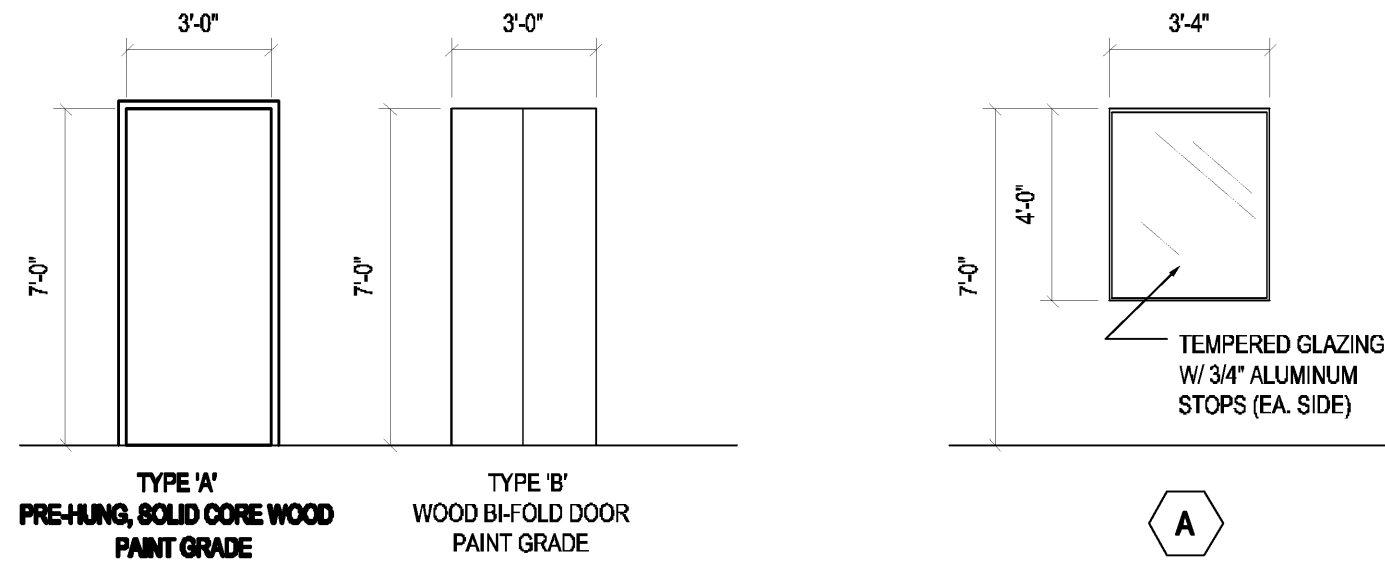

DOOR ELEVATION
SCALE: 1/4" = 1'-0"

WINDOW ELEVATION
SCALE: 1/4" = 1'-0"

| BUILDING CODE INFORMATION | |
|---|---|
| BASED ON FLORIDA BUILDING CODE 2007 w/ 2009 REVS. | |
| BUILDING TYPE: | TYPE II B CONSTRUCTION, SPRINKLERED |
| OCCUPANCY: | GROUP F-1, FACTORY INDUSTRIAL |
| AREA CALCULATIONS: | |
| 1ST FLOOR: | 2,142 S.F. |
| WAREHOUSE: | 189 S.F. |
| MEZZANINE: | 344 S.F. |
| OFFICE: | 344 S.F. |
| WAREHOUSE: | 344 S.F. |
| TOTAL TENANT AREA = | 7,875 S.F. |
| LIFE SAFETY SYSTEM: | |
| Emergency Lighting and Exit Signs | <input checked="" type="checkbox"/> Yes <input type="checkbox"/> No |
| Fire Alarm and Smoke Detection Systems | <input checked="" type="checkbox"/> Yes <input type="checkbox"/> No |
| Panel Hardware | <input checked="" type="checkbox"/> Yes <input type="checkbox"/> No |
| EXIT REQUIREMENTS: | |
| Dead end limit-maximum condition | 50 Feet |
| Travel distance to exit-maximum condition | 300 Feet |

| CEILING LEGEND | |
|----------------|--|
| | 2x4 ARMSTRONG FINE FISSURED SQUARE LAY-IN CEILING #1729 W/ 15/16" PRELUDE XL EXPOSED TEE GRID. |
| | GYPSUM BOARD CEILING/SOFFIT |
| | 2x4 FLUORESCENT FIXTURE WITH PRISMATIC LENS |
| | 8' FLUORESCENT FIXTURE |
| | 4' FLUORESCENT FIXTURE |
| | EXIT SIGN |
| | EMERGENCY LIGHTS |
| | CEILING FAN BY TENANT |

NOTES:
REFER TO ELECTRICAL PLANS FOR FIXTURE TYPES & SCHEDULE

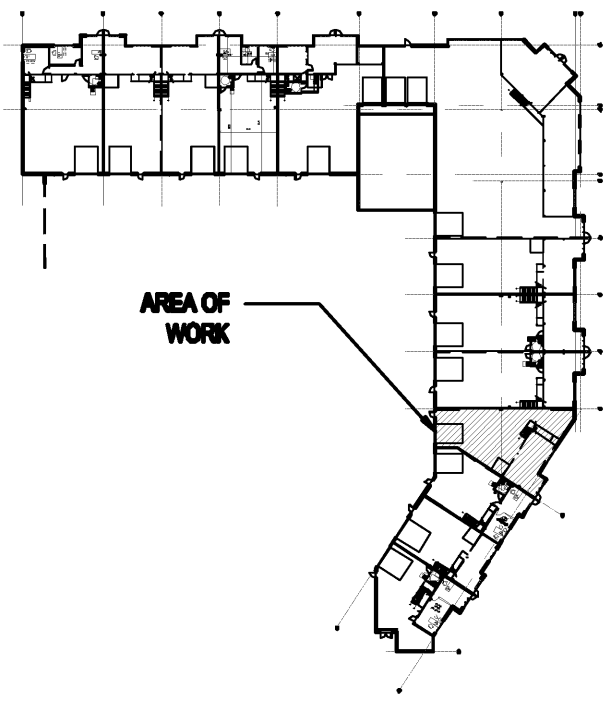

KEY PLAN
SCALE: N.T.S.

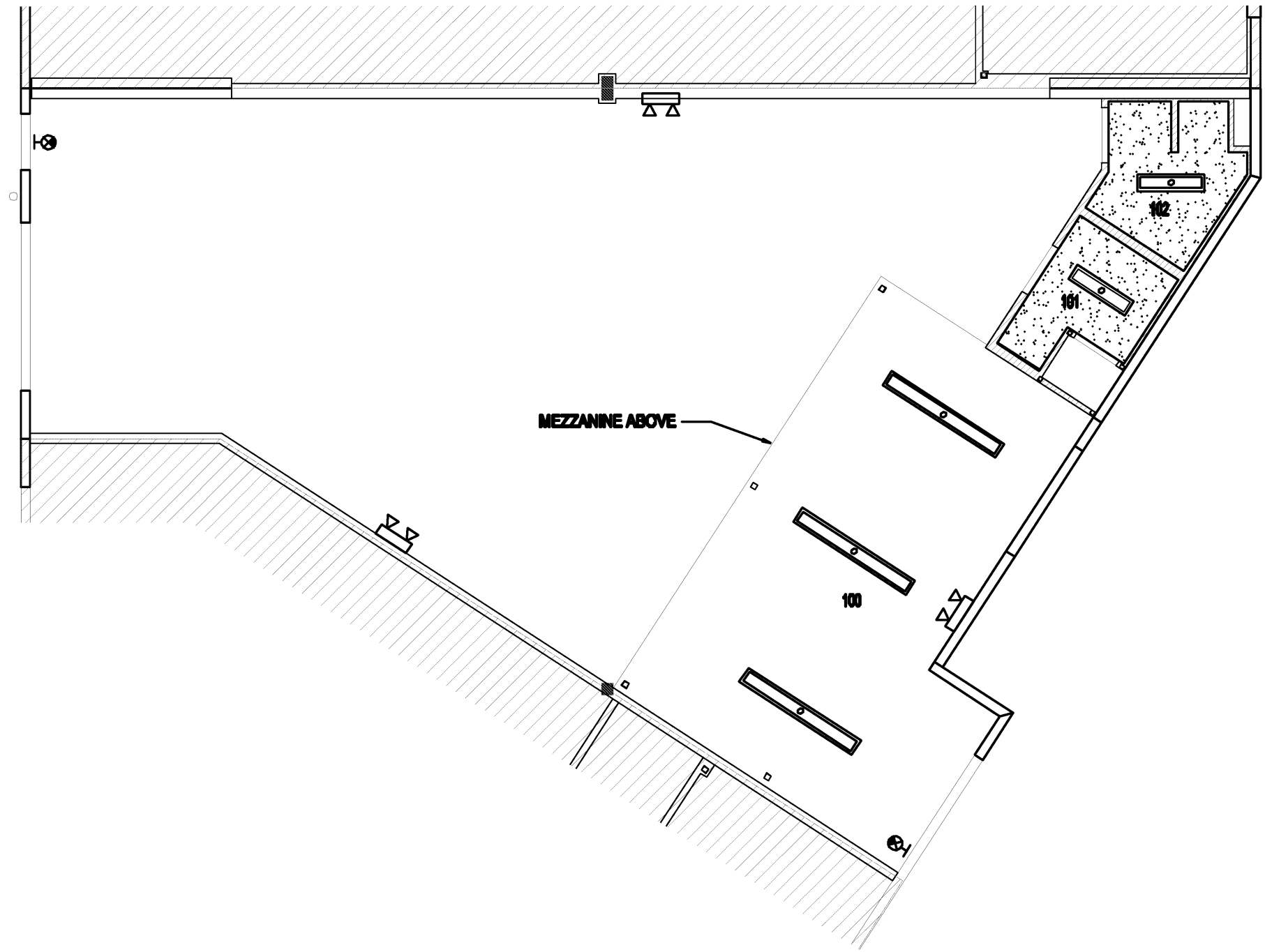

REFLECTED CEILING PLAN
SCALE: 1/8" = 1'-0"

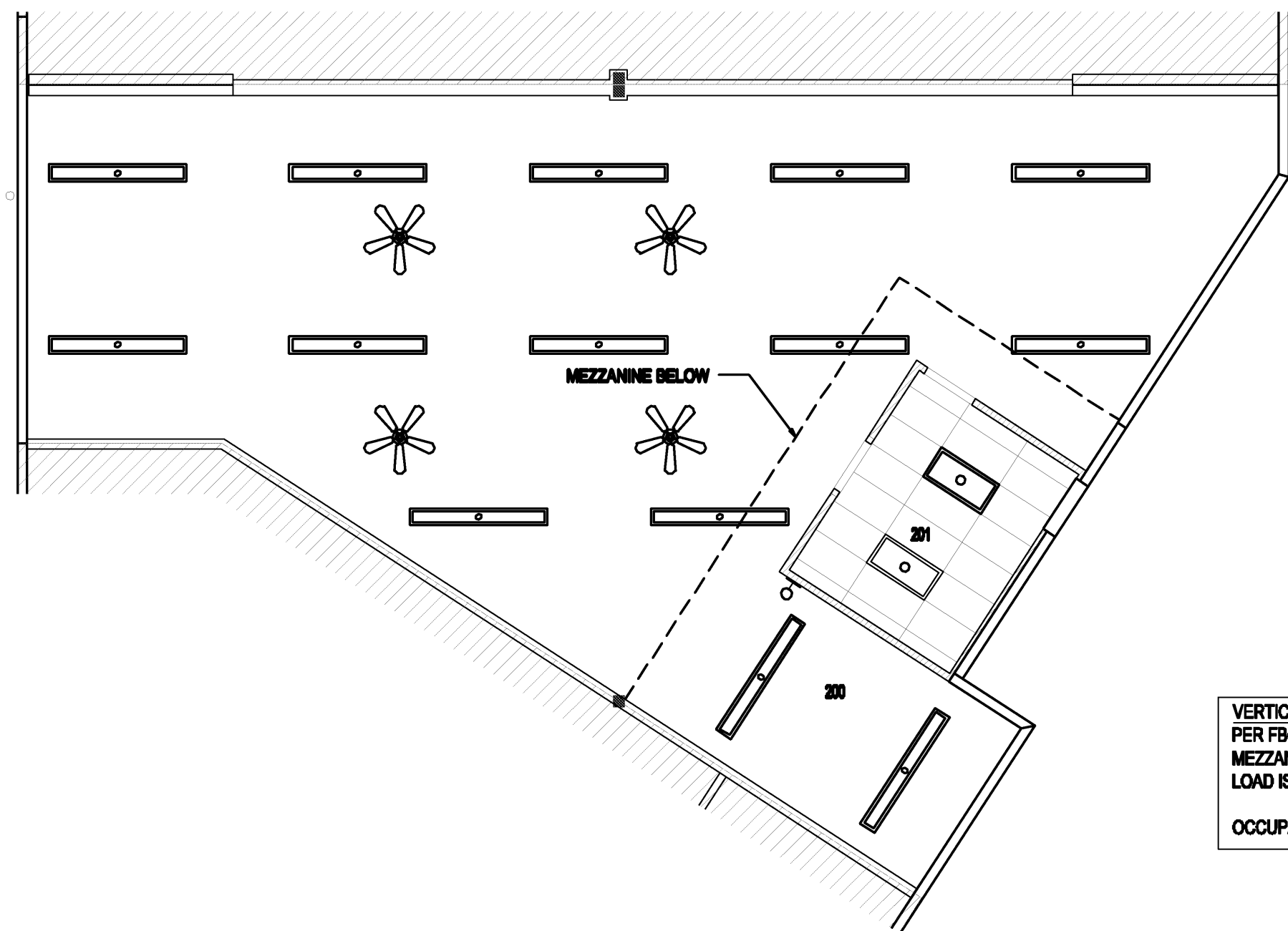

HIGH REFLECTED CEILING PLAN
SCALE: 1/8" = 1'-0"

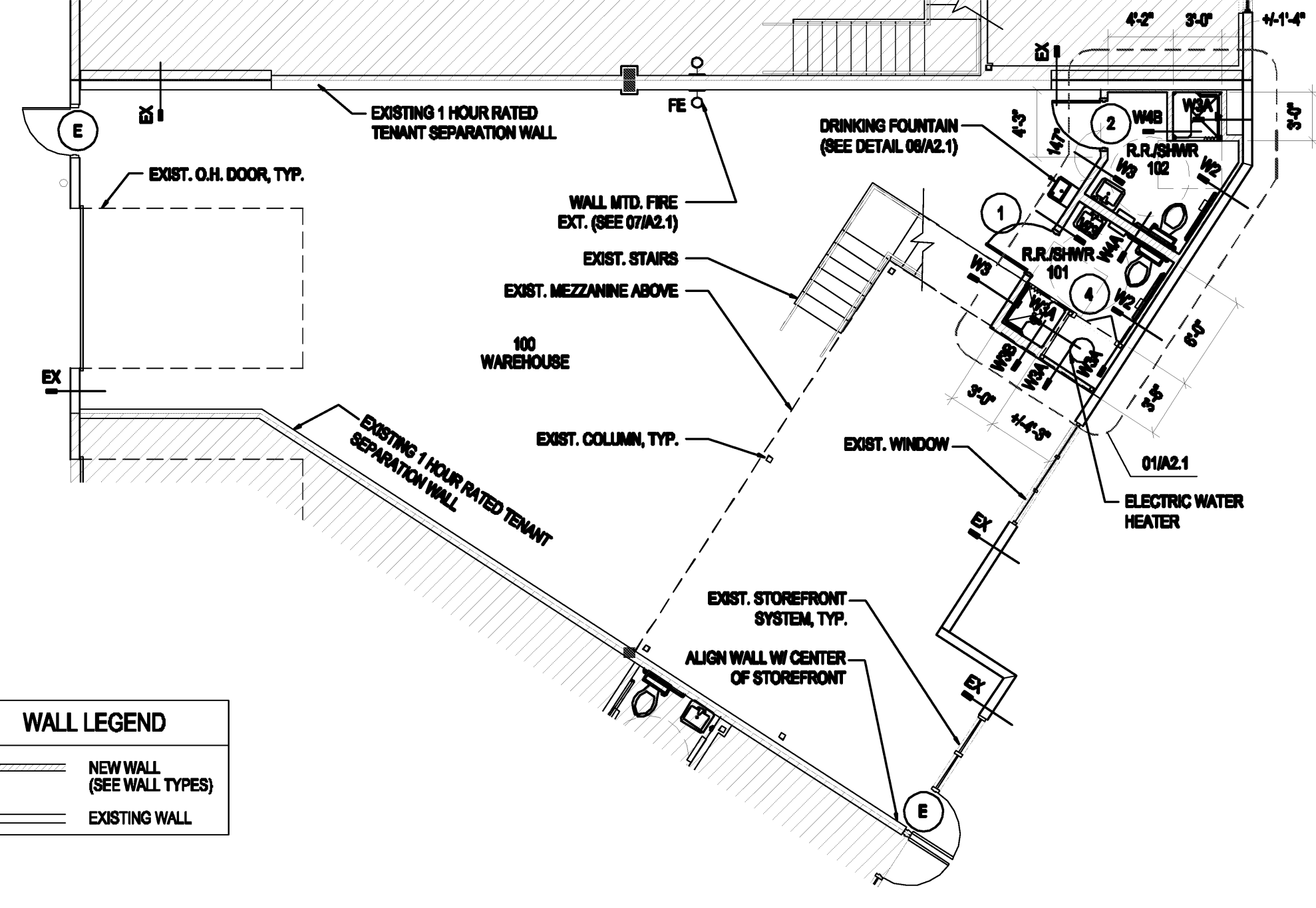

FLOOR PLAN
SCALE: 1/8" = 1'-0"

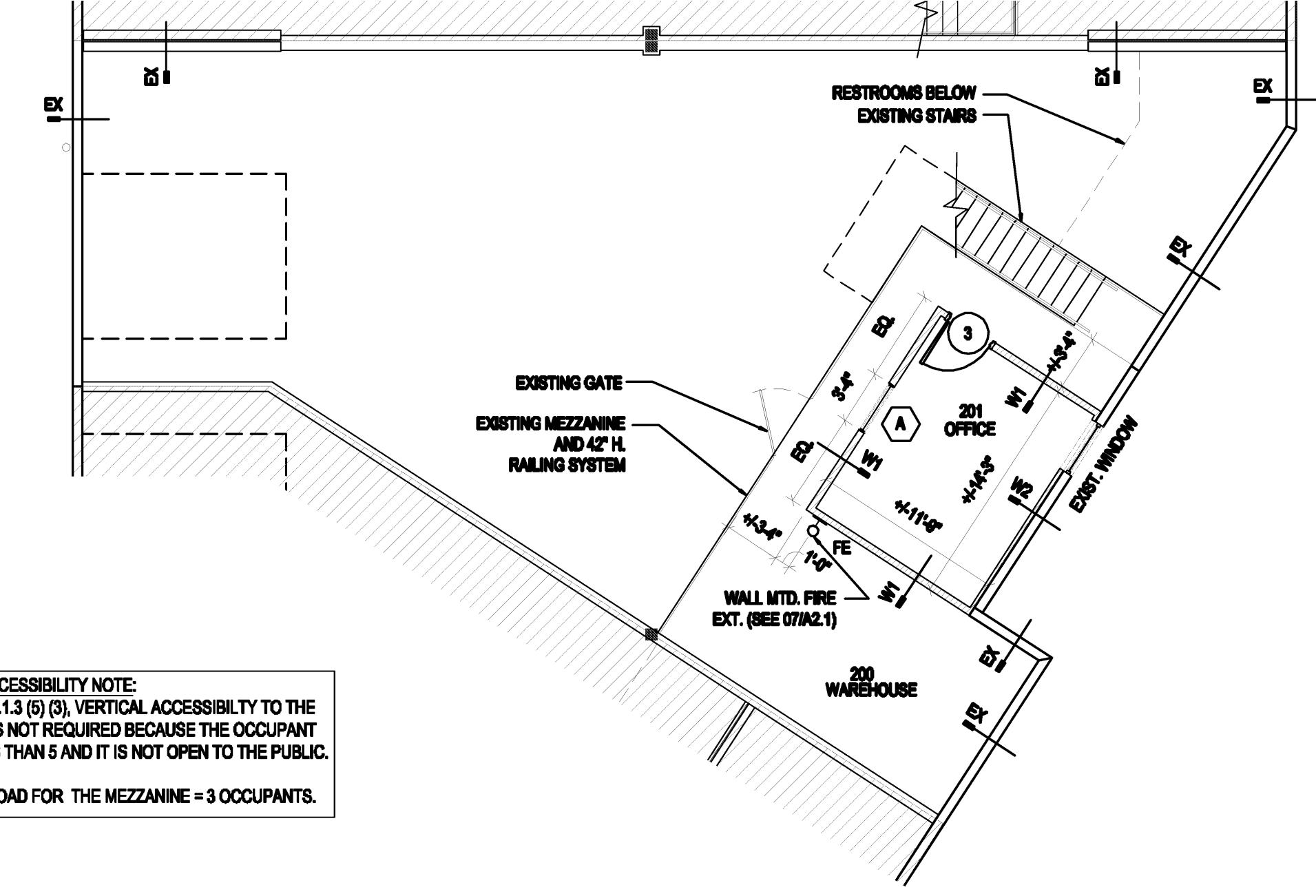

MEZZANINE PLAN
SCALE: 1/8" = 1'-0"

GENERAL NOTES

ALL CONSTRUCTION SHALL BE IN ACCORDANCE WITH ALL LOCAL AND APPLICABLE CODES.

ALL CONSTRUCTION SHALL BE IN ACCORDANCE WITH THE REQUIREMENTS AND REGULATIONS OF THE BUILDING STANDARDS AND LOCAL JURISDICTIONS.

ALL FINISH MATERIALS, HARDWARE, ETC. SHALL MATCH THE BUILDING STANDARDS UNLESS NOTED OTHERWISE. IF THE CONTRACTOR HAS DIFFICULTY MATCHING BUILDING STANDARDS, HE/SHE SHALL OBTAIN THE ARCHITECTS APPROVAL PRIOR TO SUBSTITUTING ANY ITEMS.

PROPER CARE AND PROTECTION SHALL BE PROVIDED FOR ALL AREAS ADJACENT TO CONSTRUCTION AND ANY DAMAGE THAT MAY OCCUR TO THESE AREAS AS A RESULT OF THIS CONSTRUCTION SHALL BE PROMPTLY REPAIRED BY THE CONTRACTOR TO THE ORIGINAL CONDITION.

ANY WORK THAT MUST BE PERFORMED IN OTHER TENANT SPACES IN RELATION TO THIS CONSTRUCTION SHALL BE PERFORMED IN A MANNER SO AS NOT TO DISRUPT THE OWNER, ALL WALLS, SLABS, CEILING, ETC. DISTURBED IN OTHER SPACES SHALL BE RESTORED TO ORIGINAL CONDITION ONCE WORK IS COMPLETE.

PRIOR TO CONSTRUCTION, THE CONTRACTOR SHALL REVIEW THE CONTRACT DOCUMENTS AND VERIFY ALL EXISTING CONDITIONS AND THEIR COMPATIBILITY WITH THE NEW CONSTRUCTION. THE CONTRACTOR SHALL NOTIFY THE ARCHITECT OF ANY DISCREPANCIES.

EXISTING FIRE RATINGS SHALL BE MAINTAINED AT SLAB PENETRATIONS RATED WALLS, RATED CEILING ASSEMBLIES AND FIRE COMPARTMENT ZONES.

REVIEW FINAL LOCATIONS AND QUANTITIES OF FIRE EXTINGUISHERS WITH FIRE MARSHAL PRIOR TO CONSTRUCTION.

FIRE EXTINGUISHERS SHALL BE PLACED AT INTERVALS NOT EXCEEDING A TRAVEL DISTANCE OF 75.

VERTICAL ACCESSIBILITY NOTE:
PER FCC 114.1.3 (5) (3), VERTICAL ACCESSIBILITY TO THE MEZZANINE IS NOT REQUIRED BECAUSE THE OCCUPANT LOAD IS LESS THAN 5 AND IT IS NOT OPEN TO THE PUBLIC.
OCCUPANT LOAD FOR THE MEZZANINE = 3 OCCUPANTS.

tercilla Couryemanche architects
AA 0008414
2047 vista parkway, suite 100
west palm beach, florida 33411 ph: 561.478.4457 fx: 561.478.4102

Tenant Improvement for:
Building B, Bay 10
Southern Park of Commerce
Palm Beach County, FL

| | |
|------------|-------------|
| commission | 211059 |
| date: | 9-21-11 |
| revision | date |
| no. | ▲ |
| | ▲ |
| | ▲ |
| | ▲ |
| | ▲ |
| | ▲ |
| | ▲ |
| drawing | A1.1 |

copyright 2011

THE CONTENTS OF THESE DOCUMENTS, INCLUDING OF THE DESIGN ARE COPYRIGHTED AND PROPRIETARY. THE ARCHITECT SHALL USE ALL LEGAL AGENCIES AVAILABLE TO PROTECT SAID COPYRIGHT. ANY USE NOT AUTHORIZED IN WRITING BY THE ARCHITECT IS PROHIBITED.

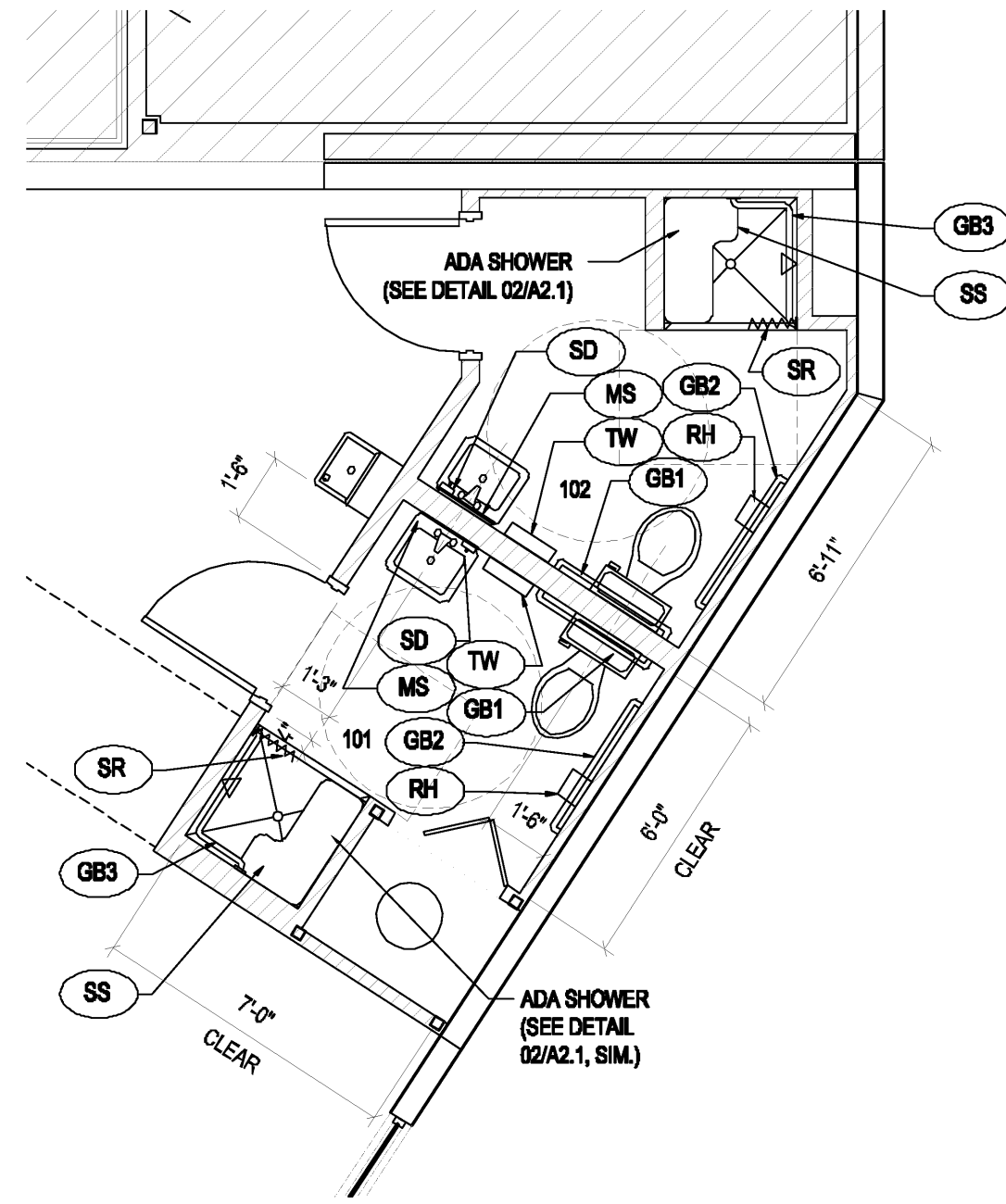

01 ENLARGED RESTROOMS
SCALE: 1/4"=1'-0"

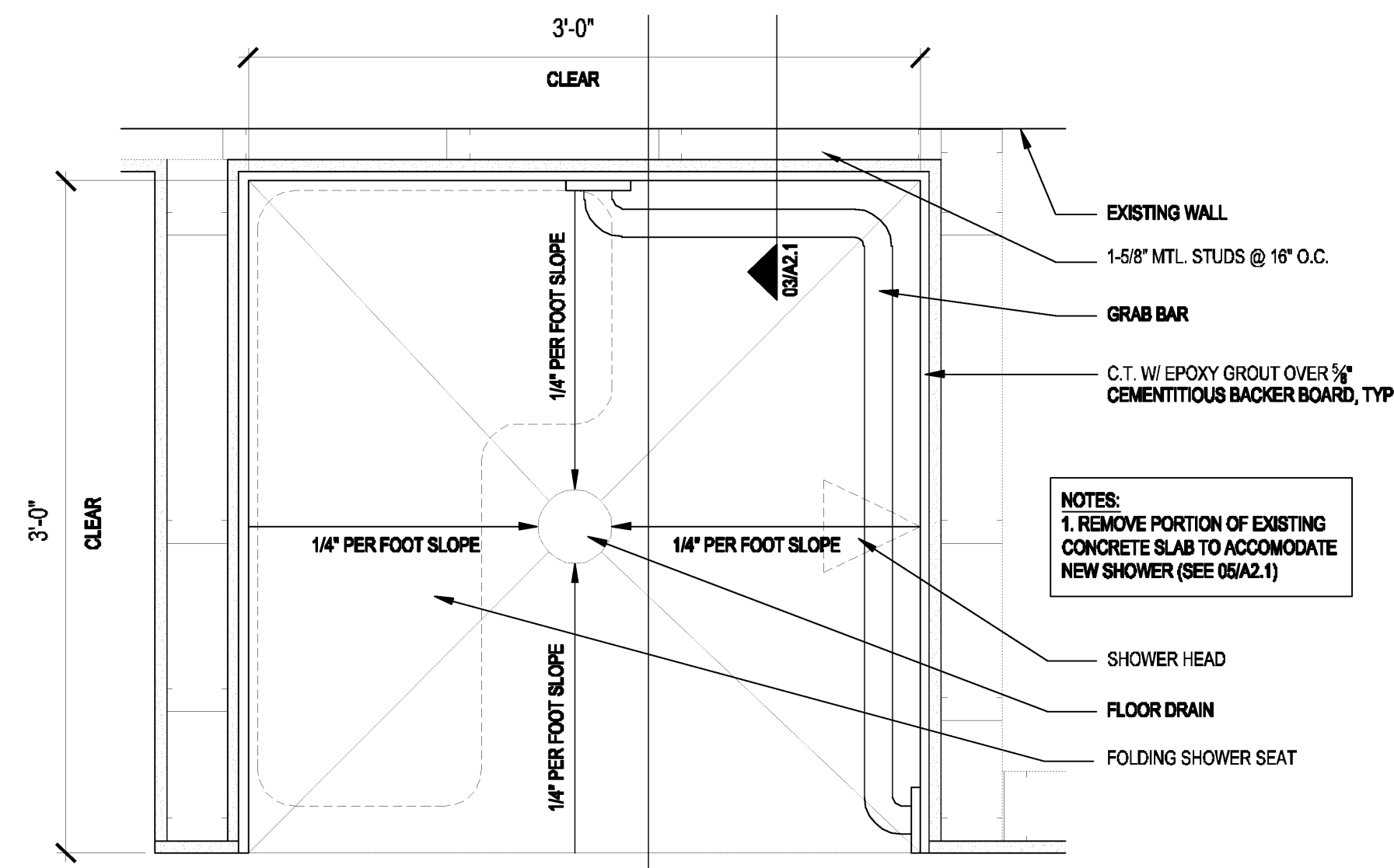

02 SHOWER PLAN
SCALE: 1-1/2"=1'-0"

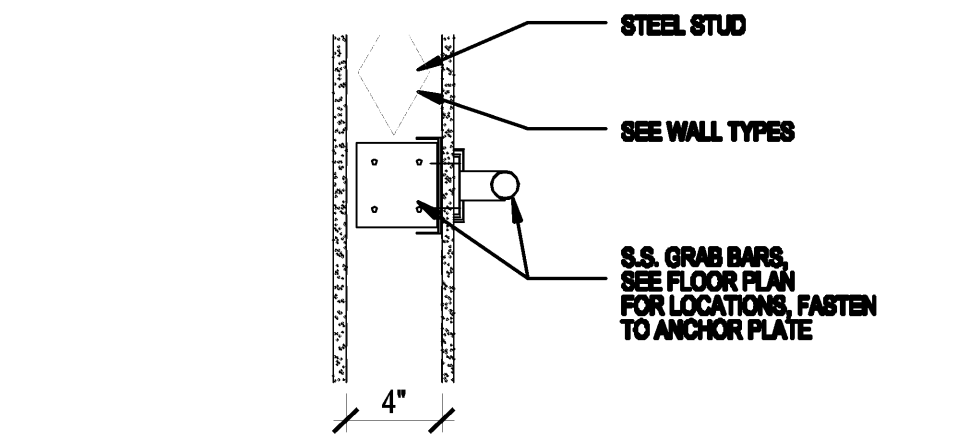

03 GRAB BAR SUPPORT DETAIL
SCALE: 1-1/2"=1'-0"

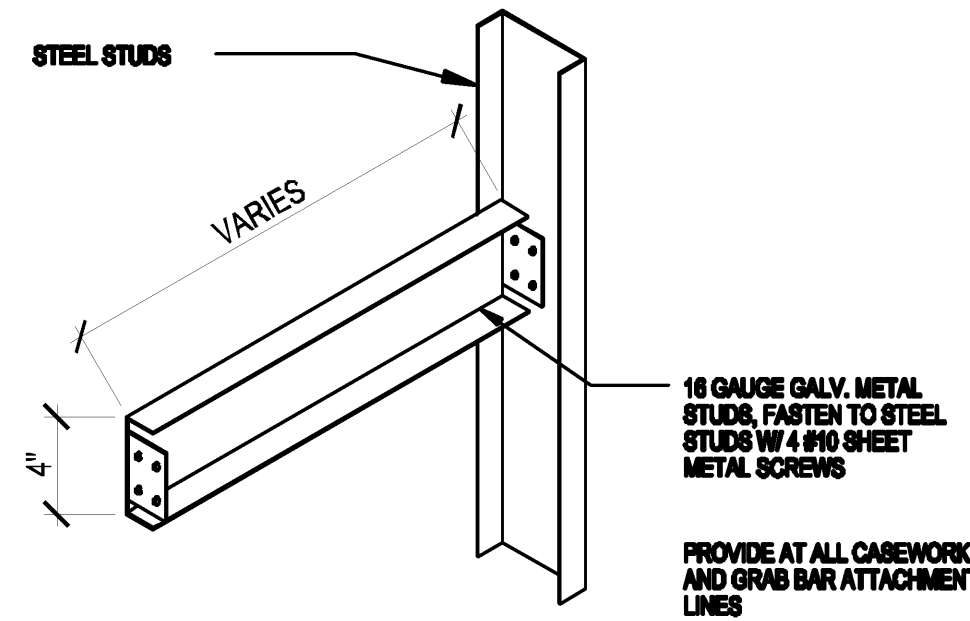

04 GRAB BAR SUPPORT DETAIL
SCALE: 1-1/2"=1'-0"

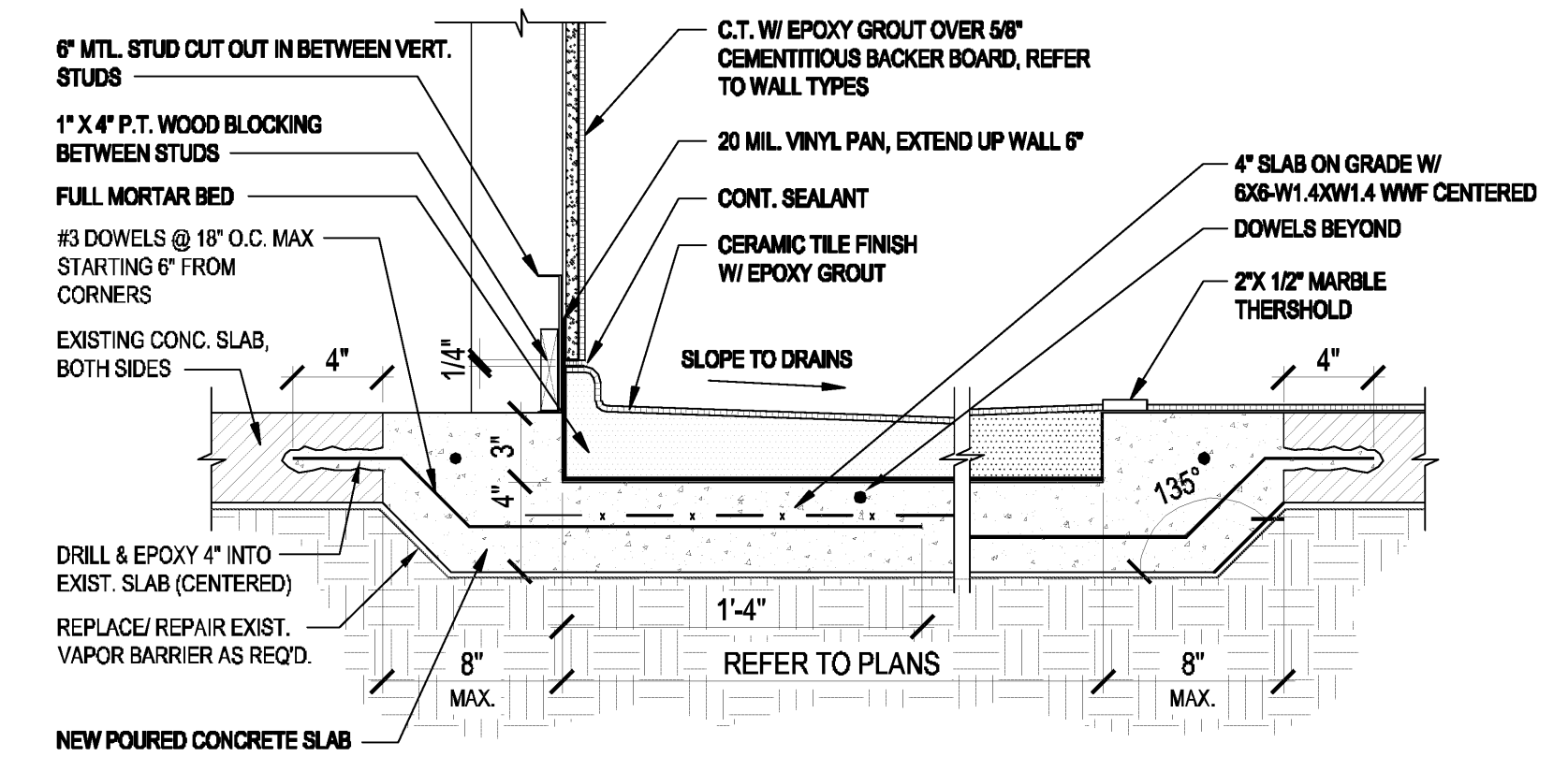

05 SHOWER RECEPTOR DETAIL
SCALE: 1-1/2"=1'-0"

| RESTROOM ACCESSORIES | |
|----------------------|---|
| GB1 | 30\"/> |
| GB2 | 42\"/> |
| GB3 | L-SHAPED SHOWER GRAB BAR (BOBRICK B-8821 OR EQUAL) |
| MS | 18\"/> |
| TW | SURFACE MOUNTED PAPER TOWEL DISPENSER (BOBRICK B-282 OR EQUAL) |
| SD | SURFACE MOUNTED SOAP DISPENSER (BOBRICK B-2111 OR EQUAL) |
| RH | TOILET TISSUE DISPENSER (BOBRICK B-7857 OR EQUAL) |
| SS | RETRACTABLE SHOWER SEAT (BOBRICK B-9181 OR EQUAL) |
| SR | SHOWER ROD (BOBRICK B-20736 OR EQUAL) HEAVY DUTY SHOWER CURTAIN ROD W/ CONCEALED MOUNTING, MODEL No. 204-2 VINYL SHOWER CURTAIN AND No. 204-1 STAINLESS STEEL SHOWER HOOKS |

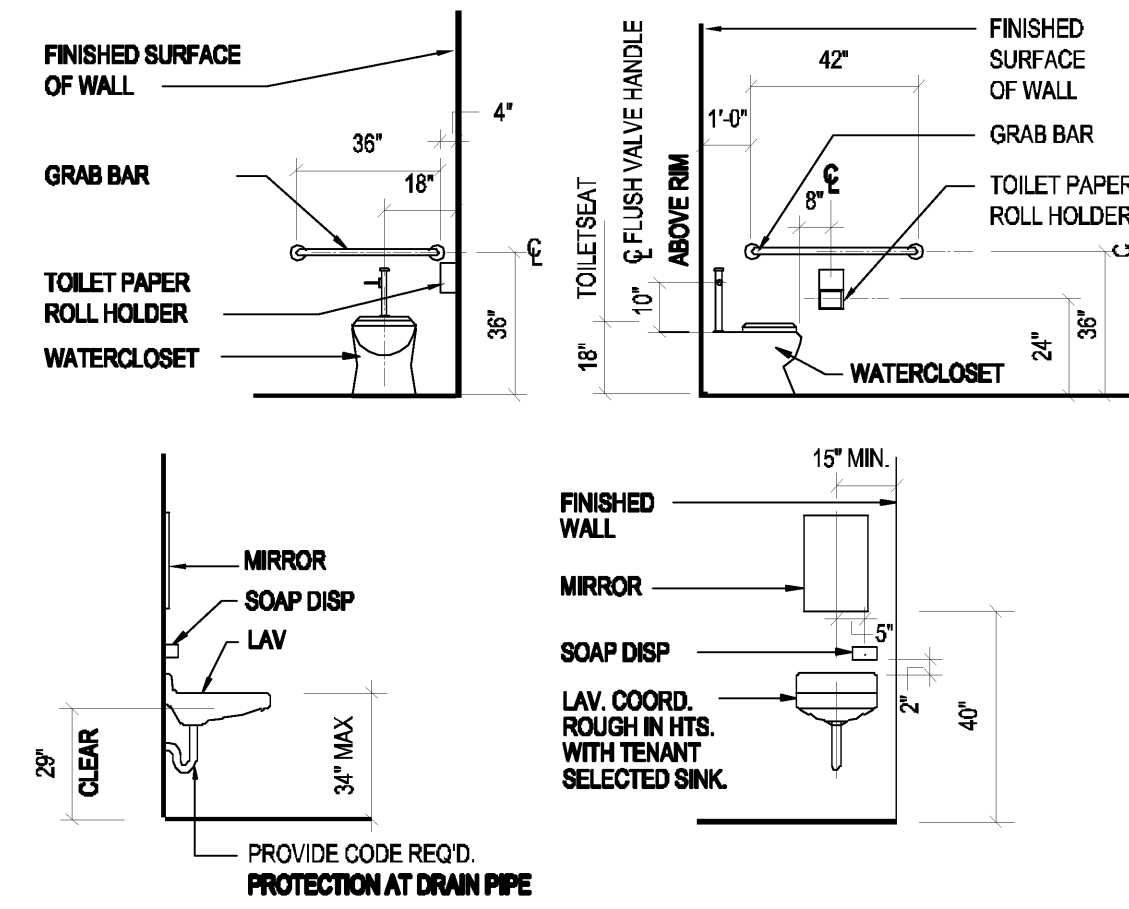

06 TYP. MTG. HEIGHTS
SCALE: N.T.S.

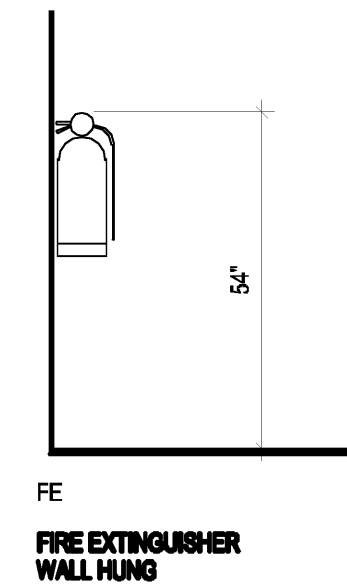

07 FIRE EXTINGUISHER DETAIL
SCALE: 1 1/2"=1'-0"

NOTE:
ACCESSIBLE DRINKING FOUNTAIN SHALL BE MOUNTED PER FBC 11-4.15. PROVIDE CUP DISPENSER TO ACCOMMODATE THOSE WHO HAVE DIFFICULTY BENDING, PER FBC 11-4.1.3 (10). CUP DISPENSER SHALL BE BOBRICK B-235 OR EQUAL.

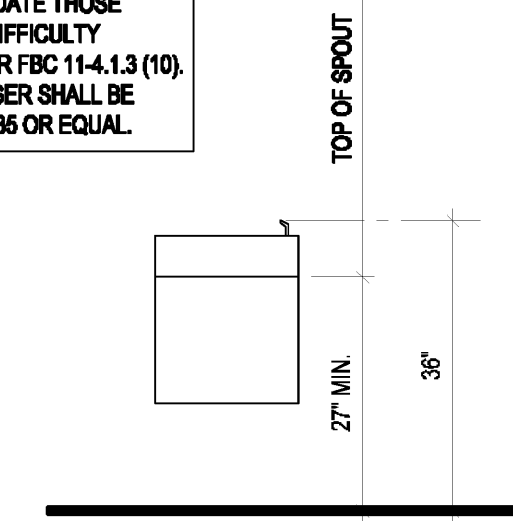

08 DRINKING FOUNTAIN DETAIL
SCALE: 1 1/2"=1'-0"

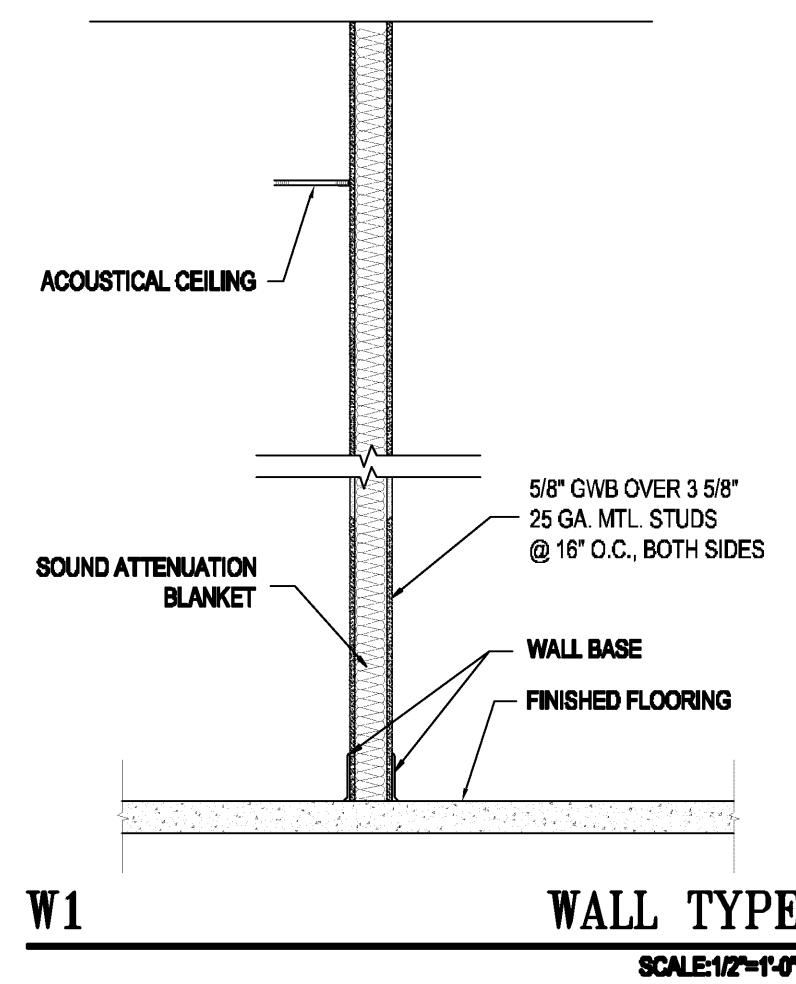

W1 WALL TYPE
SCALE: 1/2"=1'-0"

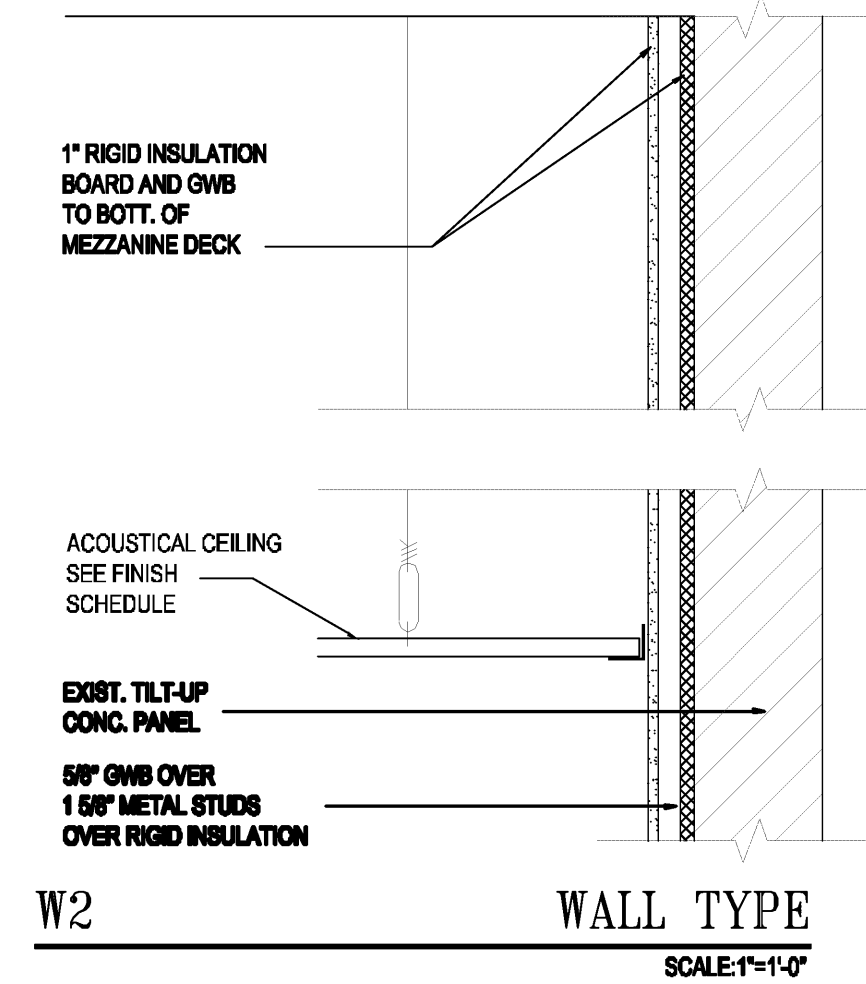

W2 WALL TYPE
SCALE: 1"=1'-0"

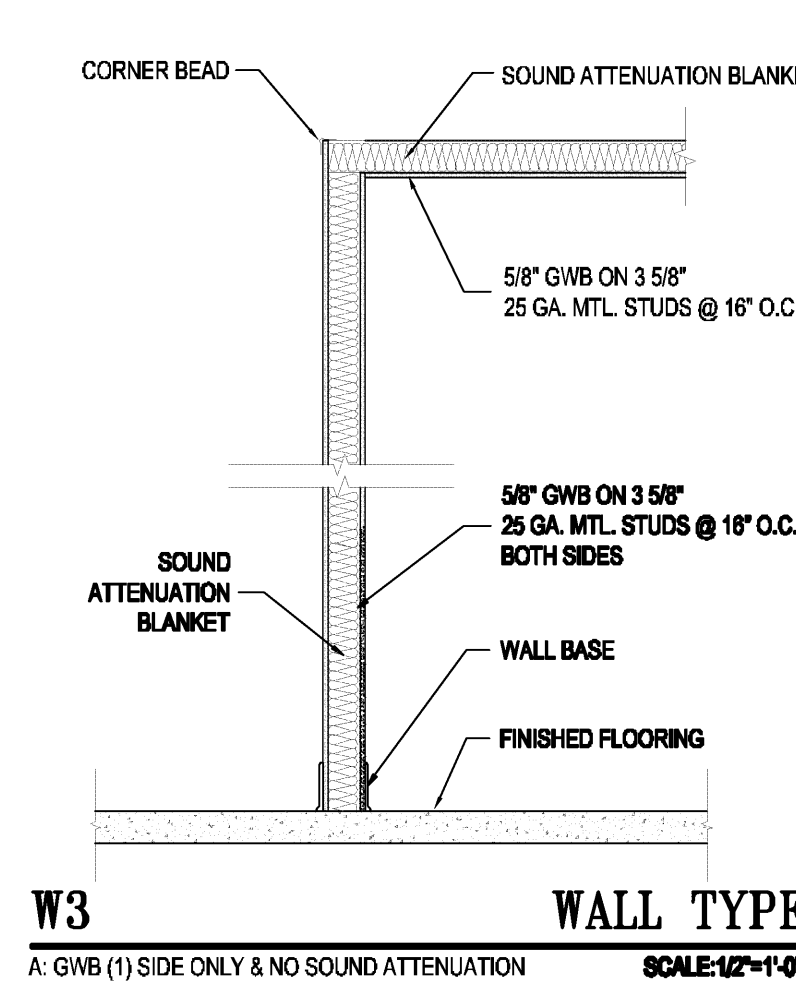

W3 WALL TYPE
SCALE: 1/2"=1'-0"

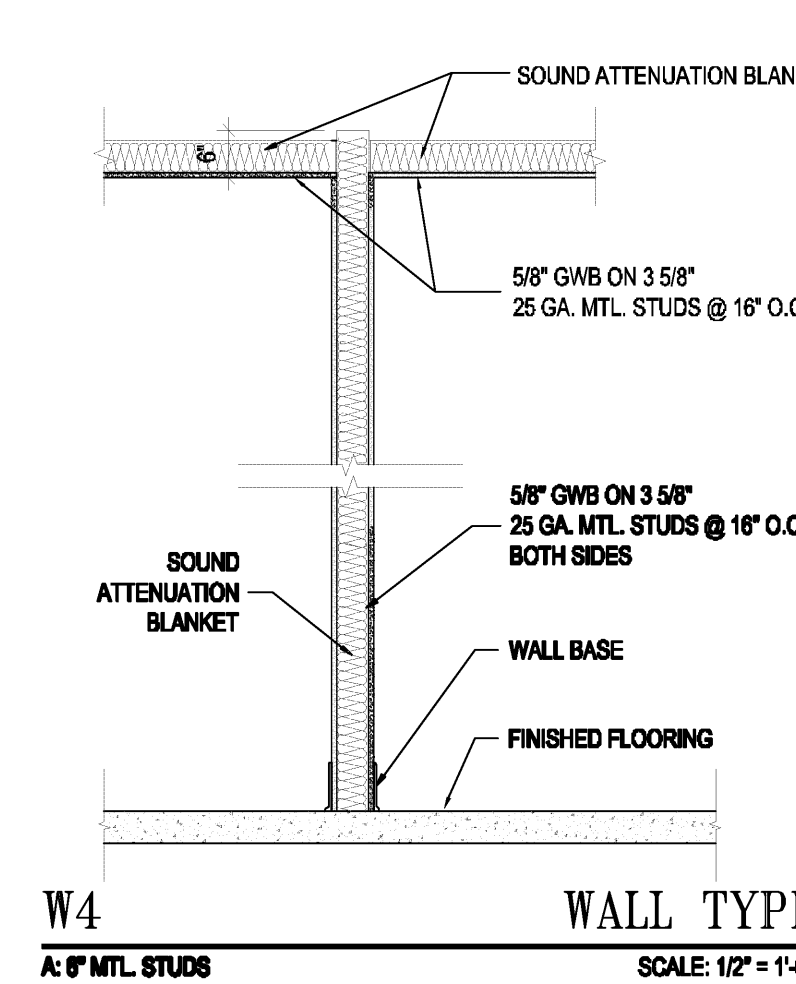

W4 WALL TYPE
SCALE: 1/2"=1'-0"

tercilla Courtemanche architects
AA 0008414
2047 vista parkway, suite 100
west palm beach, florida 33411 ph: 561.478.4457 fx: 561.478.4102

Tenant Improvement for:
Building B, Bay 10
Southern Park of Commerce
Palm Beach County, FL

| | |
|------------|---------|
| commission | 211059 |
| date: | 9-21-11 |
| revision | date |
| no. | △ |
| | △ |
| | △ |
| | △ |
| | △ |
| | △ |
| | △ |
| drawing | |

A2.1

copyright 2011

THE CONTENTS OF THESE DOCUMENTS, INCLUDING OF THE DESIGN ARE COPYRIGHTED AND PROPRIETARY. THE ARCHITECT SHALL USE ALL LEGAL AGENCIES AVAILABLE TO PROTECT SAID COPYRIGHT. ANY USE NOT AUTHORIZED IN WRITING BY THE ARCHITECT IS PROHIBITED.

PLUMBING NOTES

1. ALL WORKMANSHIP AND MATERIALS SHALL BE IN STRICT ACCORDANCE WITH APPLICABLE LOCAL CODES, RULES AND ORDINANCES.
2. PLUMBING CONTRACTOR SHALL VISIT THE JOB SITE AND THOROUGHLY FAMILIARIZE HIMSELF WITH ALL EXISTING CONDITIONS.
3. ALL MATERIALS SHALL BE NEW.
4. REQUIRED INSURANCE SHALL BE PROVIDED BY THE PLUMBING CONTRACTOR FOR PROTECTION AGAINST PUBLIC LIABILITY AND PROPERTY DAMAGE FOR THE DURATION OF THE WORK.
5. PLUMBING CONTRACTOR SHALL SECURE AND PAY FOR ALL PERMITS, FEES, INSPECTIONS AND TESTS. PLUMBING CONTRACTOR TO OBTAIN PERMIT AND APPROVED SUBMITTALS PRIOR TO BEGINNING WORK OR ORDERING EQUIPMENT. PLUMBING CONTRACTOR MUST BE PRESENT FOR ALL INSPECTIONS OF HIS WORK BY REGULATORY AUTHORITIES.
6. DRAWINGS ARE DIAGRAMMATIC. DO NOT SCALE FOR THE EXACT LOCATION OF FIXTURES, PIPING AND EQUIPMENT.
7. ALL WORK SHALL BE COORDINATED WITH OTHER TRADES TO AVOID INTERFERENCE WITH THE PROGRESS OF CONSTRUCTION. REPORT ANY DISCREPANCY TO ENGINEER/ARCHITECT PRIOR TO BEGINNING CONSTRUCTION.
8. VERIFY LOCATION, SIZE, DIRECTION OF FLOW AND INVERTS OF ALL EXISTING UTILITIES PRIOR TO BEGINNING OF CONSTRUCTION. ADVISE ENGINEER OF ANY DISCREPANCIES.
9. DOMESTIC WATER PIPE SHALL BE TYPE "L" COPPER WITH NO LEAD SOLDER.
10. SOIL, WASTE, VENT, & STORM PIPING SHALL BE CAST IRON OR SCH 40 PVC IF CODE PERMITS.
11. DIELECTRIC COUPLINGS ARE REQUIRED BETWEEN ALL DISSIMILAR METAL IN PIPING AND EQUIPMENT CONNECTIONS.
12. ISOLATE COPPER PIPE FROM HANGER OR SUPPORTS WITH ISOLATOR PAD.
13. ALL FIRE RATED FLOOR AND WALL PENETRATIONS SHALL BE PROPERLY PROTECTED BY FILLING VOIDS BETWEEN PIPE AND WALL/FLOOR SLEEVES.
14. PLUMBING CONTRACTOR SHALL GUARANTEE ALL MATERIALS AND WORKMANSHIP FREE FROM DEFECTS FOR A PERIOD OF NOT LESS THAN ONE (1) YEAR FROM DATE OF ACCEPTANCE BY OWNER. CORRECTION OF ANY DEFECTS SHALL BE COMPLETED WITHOUT ADDITIONAL CHARGE AND SHALL INCLUDE REPLACEMENT OR REPAIR OF ANY OTHER PHASE OF THE INSTALLATION WHICH MAY HAVE BEEN DAMAGED.
15. PROVIDE ACCESS PANELS FOR ALL CONCEALED VALVES. ACCESS PANELS IN RATED WALLS MUST MAINTAIN THE SAME RATING AND MUST MATCH THE FINISH OF THE WALL IN WHICH IT IS INSTALLED.
16. PROVIDE CHROME PLATED COMBINATION COVER PLATE AND CLEAN OUT PLUG OR ACCESS PANEL FOR ALL WALL CLEAN OUT.
17. ALL CONTROL VALVES SHALL BE TAGGED AND MARKED. A REPRODUCIBLE DIAGRAM LOCATING ALL VALVES SHALL BE PROVIDED FOR OWNER/OPERATOR.
18. ALL CONDENSATE DRAIN PIPING SHALL BE SCH 40 PVC WITH 1/2" THICK TYPE "C" CELLULAR FOAM INSULATION, K=0.28 MINIMUM.
19. TEST DOMESTIC WATER TO HYDROSTATIC PRESSURE OF 100 PSI AND REMAIN LEAK FREE FOR 24 HOURS. PROVIDE ALL NECESSARY TEST EQUIPMENT. PERFORM TEST IN PRESENCE OF OWNER'S REPRESENTATIVE. ENTER TEST RESULTS IN GENERAL CONTRACTOR JOB LOG. STERILIZE WATER PIPING WITH SOLUTION CONTAINING NOT LESS THAN 50 PARTS PER MILLION OF CHLORINE AND ALLOW TO REMAIN IN SYSTEM FOR A PERIOD OF EIGHT (8) HOURS. FLUSH SYSTEM AFTER STERILIZATION. ALL COST FOR STERILIZATION AND EQUIPMENT SHALL BE PROVIDED BY THE CONTRACTOR.
20. PROVIDE 1" (R=4.0 MIN.) INSULATION FOR ALL HOT WATER LINES.
21. ALL FIXTURES MUST BE PROVIDED WITH READILY ACCESSIBLE STOPS AND APPROPRIATELY MARKED ACCESS PANELS. COORDINATE LOCATIONS WITH GENERAL CONTRACTOR PRIOR TO INSTALLATION.
22. PROVIDE ANGLE STOPS ON ALL WATER SERVICE LINES TO FIXTURES FOR INDIVIDUAL SHUTOFF.
23. THE DESIGN AND INSTALLATION OF THE PLUMBING SYSTEM & ALL APPURTENANCES SHALL COMPLY STRICTLY WITH THE APPLICABLE PROVISIONS OF THE FLORIDA BUILDING PLUMBING CODE & THE LOCAL AMENDMENTS TO THE FLORIDA BUILDING PLUMBING CODE.

MECHANICAL LEGEND

- 24x24 PERFORATED CEILING DIFFUSER.
- 24x24 PERFORATED RETURN/TRANSFER GRILLE.
- SIDEWALL SUPPLY AIR REGISTER (SAR).
- SIDEWALL RETURN GRILLE (SAG).
- EXHAUST FAN.
- CURVED BLADE CEILING DIFFUSER (CBCD).
- RIGID DUCTWORK.
- FLEXIBLE DUCTWORK.
- MANUAL VOLUME DAMPER.
- WALL MOUNTED THERMOSTAT.
- DUCT MOUNTED SMOKE DETECTOR.
- EMERSON HEAT FAN CONTROLS.

AIR DISTRIBUTION SCHEDULE-BASED ON TITUS

| MODEL | MATERIAL | DEVICE | REMARKS |
|-----------|----------|---|--------------|
| 250-AA | ALUMINUM | CURVED BLADE CEILING DIFFUSER | W/OBD NOTE 1 |
| P45-AA | ALUMINUM | 24x24 PERFORATED SUPPLY GRILLE | NOTE 2 |
| P48-AA | ALUMINUM | 24x24 PERFORATED RETURN GRILLE | W/OBD NOTE 2 |
| 300-FS-AA | ALUMINUM | DOUBLE DEFLECTION, ADJUSTABLE BLADE SIDEWALL DIFFUSER | W/OBD NOTE 1 |

- NOTES:
 1. USE BORDER TYPE 1 FOR SURFACE MOUNT.
 2. USE BORDER TYPE 3 FOR LAY-IN CEILING.

PLUMBING FIXTURE SCHEDULE

| MARK | FIXTURE | DESCRIPTION | TRIM | REMARKS |
|------|-------------|---------------------------|---|-------------------|
| 1 | H. C. V. C. | A/S 2216.170 CABET 1.6GPF | OPEN FRONT SEAT ELONGATED BOWL. | HANDICAP 17" HIGH |
| 2 | LAVATORY | A/S 0124.024 CORABE | A/S S402.172H FAUCET W/WRIST HANDLES AND GRID DRAIN AND 0.5 GPM FLOW RESTRICTOR | WALL MTD |
| 3 | ENC | DASIS PBAC | W/ PAPER CUP HOLDER | |
| 4 | SHOWER TRIM | A/S 1662.221 | COMMERCIAL SHOWER TRIM KIT. | ADA COMPLIANT. |

GENERAL MECHANICAL NOTE

1. VISIT THE SITE BEFORE SUBMITTING A BID. DETERMINE THE CHARACTERISTICS OF EXISTING FACILITIES WHICH WILL AFFECT PERFORMANCE OF THE WORK, BUT WHICH ARE NOT SHOWN ON THE DRAWINGS OR THE SPECIFICATIONS.
2. SHOP DRAWINGS OR FULLY DESCRIPTIVE CATALOG DATA SHALL BE SUBMITTED BY THE CONTRACTOR FOR ALL KINDS OF MATERIAL AND EQUIPMENT FURNISHED AND INSTALLED UNDER THIS CONTRACT. THE CONTRACTOR SHALL SUBMIT TO THE ARCHITECT A SUFFICIENT NUMBER OF COPIES OF ALL SUCH SHOP DRAWINGS OR CATALOG DATA TO PROVIDE HIM WITH AS MANY REVIEWED COPIES AS HE MAY NEED, PLUS TWO (2) COPIES FOR RETENTION BY THE ARCHITECTS AND ENGINEERS.
3. ALL CUTTING, PATCHING, STRUCTURAL STEEL, WEATHER PROOFING, PAINTING, AND WALL OPENINGS SHALL BE BY THE GENERAL CONTRACTOR.
4. ALL OPENINGS IN BUILDING STRUCTURE, FOR DUCTWORK, PIPING, ETC. TO BE 1/2" LARGER (ON ALL SIDES) THAN THE OUTSIDE DIMENSIONS. FILL VOIDS WITH FIRE RETARDANT SILICONE FOAM (I.E. CHASE-FOAM CTC PR-855 BY CHASE TECHNOLOGY CORP.).
5. CONTRACTOR SHALL GUARANTEE ALL MATERIALS AND WORKMANSHIP FREE FROM DEFECTS FOR A PERIOD OF NOT LESS THAN ONE (1) YEAR FROM DATE OF ACCEPTANCE. CORRECTION OF ANY DEFECTS SHALL BE COMPLETED WITHOUT ADDITIONAL CHARGE AND SHALL INCLUDE REPLACEMENT OR REPAIR OF ANY OTHER PHASE OF THE INSTALLATION WHICH MAY HAVE BEEN DAMAGED.

GENERAL HVAC NOTES

1. VISIT THE SITE PRIOR TO SUBMITTING A BID. DETERMINE THE CHARACTERISTICS OF EXISTING FACILITIES WHICH WILL AFFECT PERFORMANCE OF THE WORK, BUT WHICH ARE NOT SHOWN ON THE DRAWINGS.
2. PROVIDE ALL LABOR PERMITS, MATERIAL, TOOLS, SUPPLIES, EQUIPMENT TO INSTALL A COMPLETE AND OPERATING AIR CONDITIONING SYSTEM. INSTALLATION SHALL BE IN ACCORDANCE WITH LOCAL CODES.
3. PAY ALL COSTS OF PERMIT INSPECTIONS AND ALL OTHER COSTS INCIDENTAL TO THE COMPLETION AND TESTING OF THIS WORK.
4. CONTRACTOR SHALL SUBMIT, FOR APPROVAL FIVE (5) COPIES OF MANUFACTURERS DRAWINGS FOR EACH PIECE OF EQUIPMENT AND CONTROLS INCLUDED IN CONTRACT.
5. ALL CONDITIONED AIR DUCTWORK SHALL BE FIBERGLASS, R=6.0 MIN. EXHAUST & OUTSIDE AIR DUCTWORK SHALL BE GALVANIZED STEEL. ALL BENDS GREATER THAN 45 DEGREES SHALL HAVE TURNING VANES. CONTRACTOR SHALL VERIFY ALL CLEARANCES AND ADJUST FOR FIELD CONDITIONS PRIOR TO CONSTRUCTING ANY DUCTWORK. ALL DUCT SIZES ARE CLEAR INSIDE DIMENSIONS. INSTALL ALL DUCTWORK PER APPROPRIATE SMACNA STANDARD.
6. THE CONTRACTOR SHALL FURNISH A WRITTEN WARRANTY THAT SHALL GUARANTEE ALL WORKMANSHIP AND MATERIALS FOR ONE (1) YEAR FROM THE DATE OF FINAL ACCEPTANCE BY THE ARCHITECT. ANY BREAK-DOWN OCCURRING IN THE FIRST YEAR SHALL BE REPAIRED AT NO COST TO THE OWNER. A/C COMPRESSORS SHALL HAVE A 5 YEAR GUARANTEE.
7. PROVIDE & INSTALL ALL CONTACTORS, RELAYS, AND CONTROLS.
8. HVAC CONTRACTOR SHALL PROVIDE A TEST AND BALANCE REPORT FOR ALL MECHANICAL SYSTEMS AND EQUIPMENT. THIS REPORT SHALL INCLUDE ALL SUPPLY GRILLES, RETURN GRILLES, AND EXHAUST GRILLS AND THE LEAVING AND ENTERING AIR TEMPERATURE (T) FROM AT EACH EVAPORATOR COIL. INCLUDE ALL VOLTAGE AND AMPERAGE FOR EACH MOTOR. THE REPORT SHALL BE DONE BY AN INDEPENDENT TAB CONTRACTOR LICENSED BY THE STATE OF FLORIDA AND SUBMITTED TO THE ARCHITECT.
9. ALL AIR DEVICES (DIFFUSERS, REGISTERS AND GRILLES) SHALL BE ALL ALUMINUM CONSTRUCTION WITH EXPOSED SURFACE OFF WHITE BAKED ENAMEL FINISH OR AS SPECIFIED BY ARCHITECT. DEVICES SHALL BE TITUS OR METALAIR.
10. ALL BRANCH TAKE OFFS TO BE PROVIDED W/ MANUAL VOLUME DAMPERS. ALL ELBOWS AND TEES MUST BE FURNISHED W/TURNING VANES. PROVIDE MANUAL VOLUME DAMPERS WITH EXTRACTOR AT ALL FLEX TAKE OFFS.
11. PROVIDE NEW FILTERS FOR ALL RTU'S BEFORE STARTING THEM. REPLACE FILTERS PRIOR TO FINAL ACCEPTANCE BY OWNER.
12. FIRE DAMPERS SHALL BE STYLE B WITH THE BLADES OUT OF THE AIRSTREAM. DAMPERS FOR RECTANGULAR DUCTS SHALL BE EQUAL TO RUSKIN #1802 WITH 1 1/2 HOUR RATING & DAMPERS FOR ROUND DUCT SHALL BE EQUAL TO RUSKIN #1802-OR WITH 1 1/2 HOUR RATING.
13. ALL PENETRATIONS OF FIRE RESISTIVE ASSEMBLIES INCLUDING FLOOR ASSEMBLIES SHALL BE PROTECTED BY AN APPROVED THROUGH STOP ASSEMBLY AND INSPECTED FOR COMPLIANCE PRIOR TO CLOSE IN. THE CONTRACTOR MUST VISIT THE SITE & REVIEW THE ARCHITECTURAL PLANS PRIOR TO BID TO LOCATE ALL NEW FIRE WALLS & ANY EXISTING MECHANICAL DUCTWORK, PIPING, ETC. THAT WILL REQUIRE NEW FIRE DAMPERS OR THROUGH STOPS. ALL COSTS SHALL BE INCLUDED IN THE BID.
14. THE DESIGN & INSTALLATION OF THE MECHANICAL SYSTEMS & ALL APPURTENANCES SHALL COMPLY STRICTLY WITH THE APPLICABLE PROVISIONS OF THE FLORIDA BUILDING MECHANICAL CODE & THE LOCAL AMENDMENTS TO THE FLORIDA BUILDING MECHANICAL CODE.
15. PROVIDE A 10 FOOT MINIMUM CLEARANCE FROM ALL VENTS THROUGH ROOF (VTR) AND EXHAUST FANS TO OUTSIDE AIR INTAKES.
16. ALL STORAGE ROOMS, TOILETS, ETC. WILL HAVE UNDERCUT DOORS TO PROVIDE VENTILATION REQUIRED WHEN DOOR OR TRANSFER GRILLES ARE NOT SHOWN.
17. A/C CONTRACTOR SHALL BE RESPONSIBLE TO COORDINATE HIS WORK FOR SIZE, LOCATION, CLEARANCE, ACCESS AND ELECTRICAL CHARACTERISTICS WITH ALL OTHER TRADES AND TO PROVIDE SHOP DRAWINGS TO THE ENGINEER FOR REVIEW BEFORE INSTALLATION OF DUCTWORK OR EQUIPMENT. SHOP DRAWINGS WILL INCLUDE BEAM OR STRUCTURE ELEVATION & REQUIRED EQUIPMENT ACCESS AREAS.
18. COORDINATE LOCATION OF CEILING DIFFUSERS, GRILLES AND REGISTERS IN THE FIELD WITH LIGHTS AND ARCHITECTURAL ELEMENTS.
19. COORDINATE LOCATION OF HANGERS, THERMOSTATS, FANS AND DUCTWORK WITH BUILDING STRUCTURE AND OTHER TRADES SO THAT NO INTERFERENCES OCCUR.
20. MECHANICAL PLANS IN GENERAL, ARE DIAGRAMMATIC IN NATURE, AND ARE TO BE READ IN CONJUNCTION WITH ARCHITECTURAL, PLUMBING, ELECTRICAL AND STRUCTURAL PLANS. DUCT BENDS AND TRANSITIONS WILL BE REQUIRED TO PROVIDE AND INSTALL A COMPLETE FUNCTIONAL SYSTEM AND SHALL BE PROVIDED BY THE CONTRACTOR AT NO ADDITIONAL COST TO THE OWNER.
21. FAN DRIVES SHALL BE ADJUSTED TO DELIVER THE SPECIFIED CFM AGAINST THE ACTUAL STATIC PRESSURE OF THE INSTALLATION.
22. ALL OUTSIDE EQUIPMENT SHALL BE SECURED TO WITHSTAND 140 M.P.H. WINDS.
23. ALL UNITS SHALL BE PROVIDED W/ HONEYWELL ELECTRONIC PROGRAMMABLE THERMOSTATS.

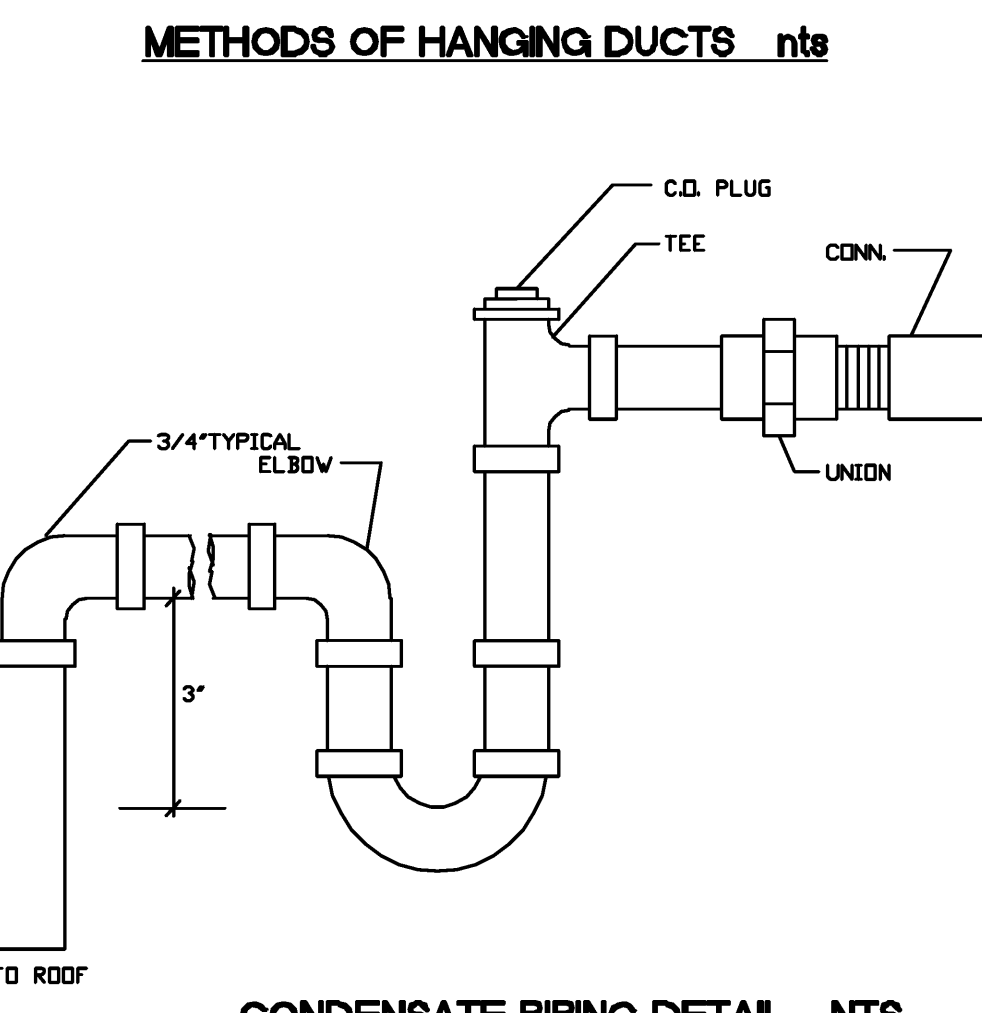
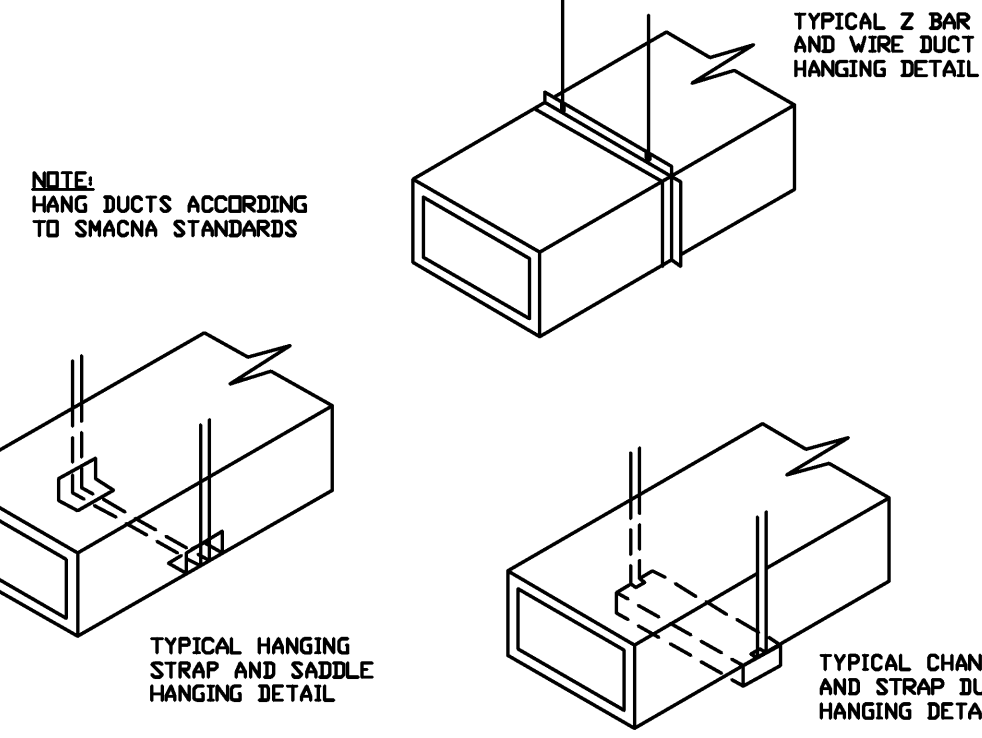
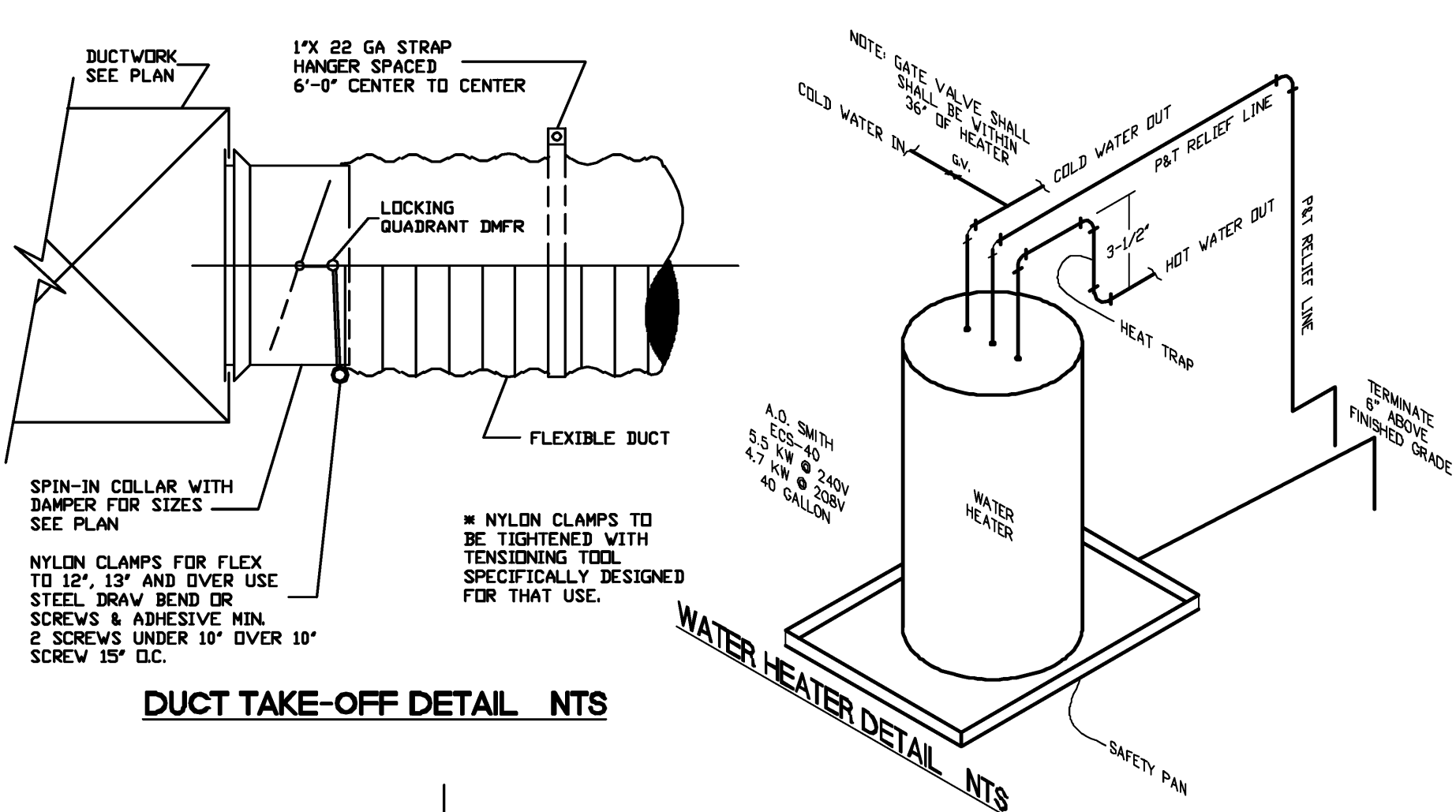

WATER ISOMETRIC DIAGRAM - NTS

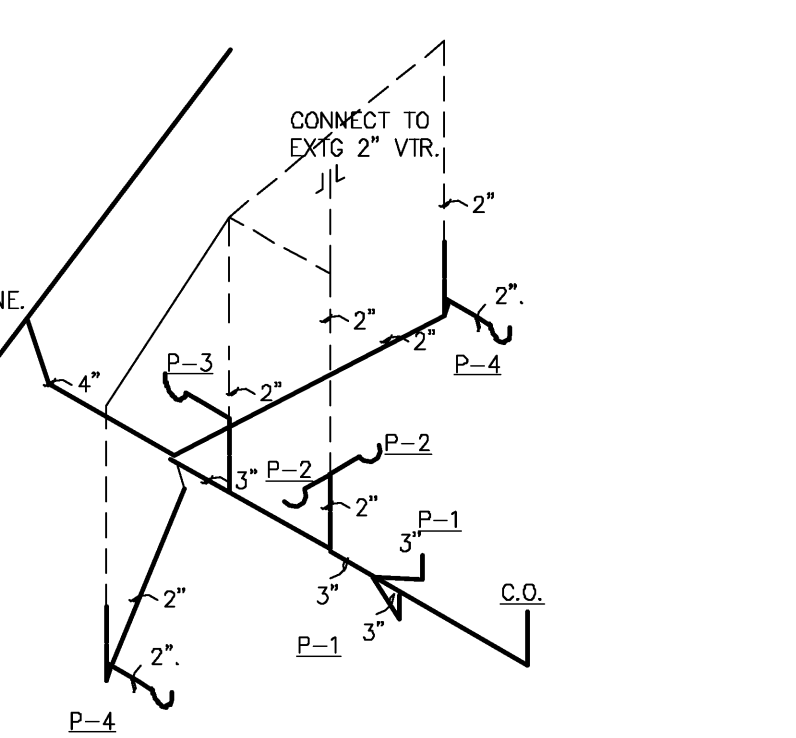

SANITARY ISOMETRIC DIAGRAM - NTS

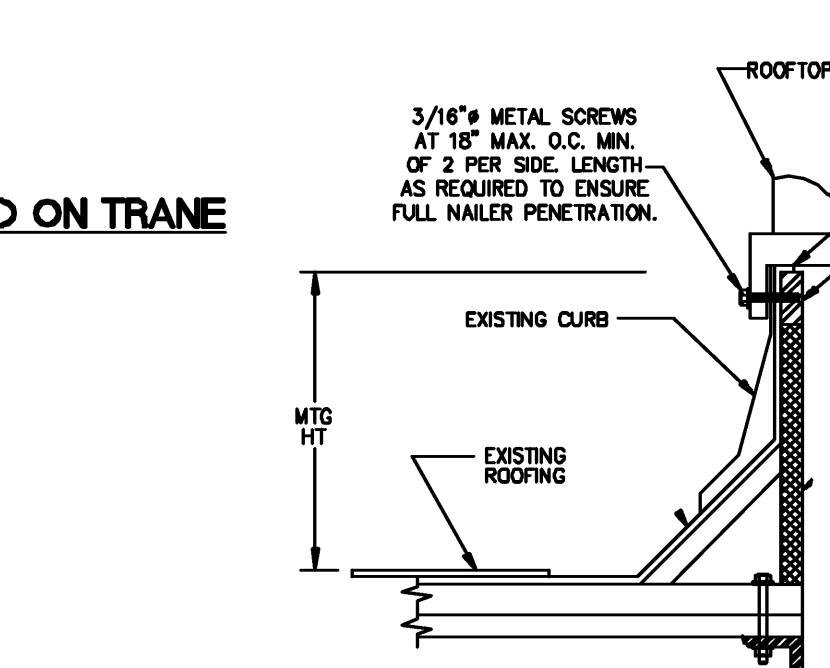

ROOFTOP SCHEDULE - BASED ON TRANE

| TYPE | 5.0 TON |
|---------------|------------|
| MODEL NO. | 4TCC3060A3 |
| TOTAL COOLING | 58500 |
| SENSIBLE | 41600 |
| CFM | 1800 |
| ELEC. HEAT-KW | 7.50 |
| COMP.FLA | 18.1 |
| OD FAN FLA | 1.4 |
| ID FAN FLA | 7.6 |
| FUSE | 50 |
| SEER | 13.0 |
| WEIGHT | 482 |
| ELECTRICAL | 208-3PH |

- NOTES:
 1. PROVIDE ROOF CURB ADAPTER TO ALLOW NEW RTU TO MOUNT ON EXISTING BAY/GORGE/DOA.
 2. MECHANICAL CONTRACTOR SHALL PROVIDE FILTER RACK IN UNIT.

SUPPORT CURB DETAIL - NTS

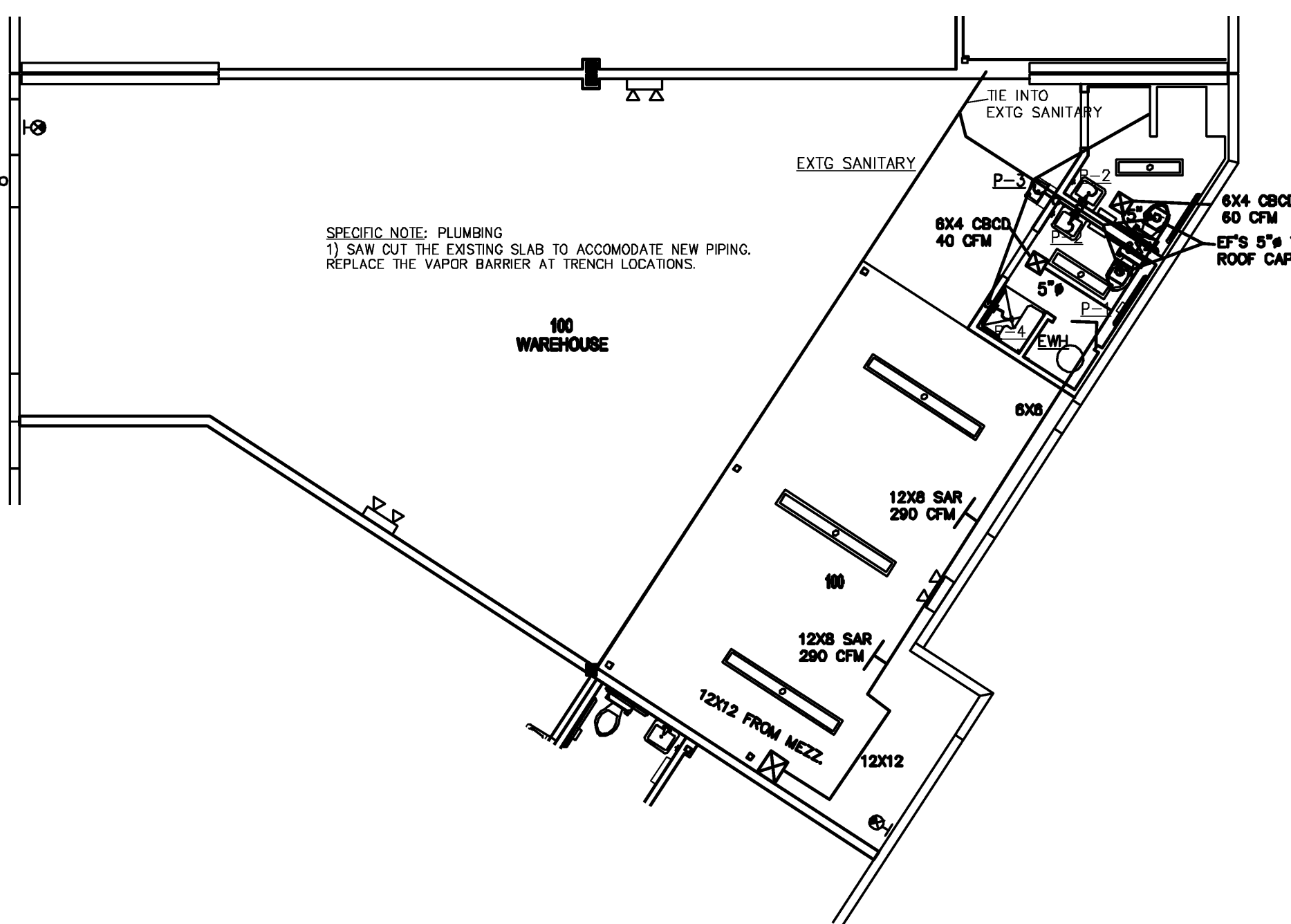
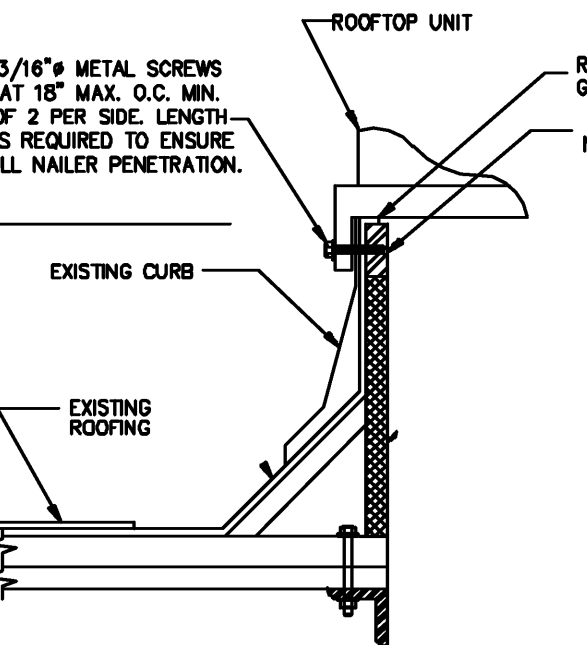

LOW PLUMBING/HVAC PLAN

SCALE: 1/8"=1'-0"

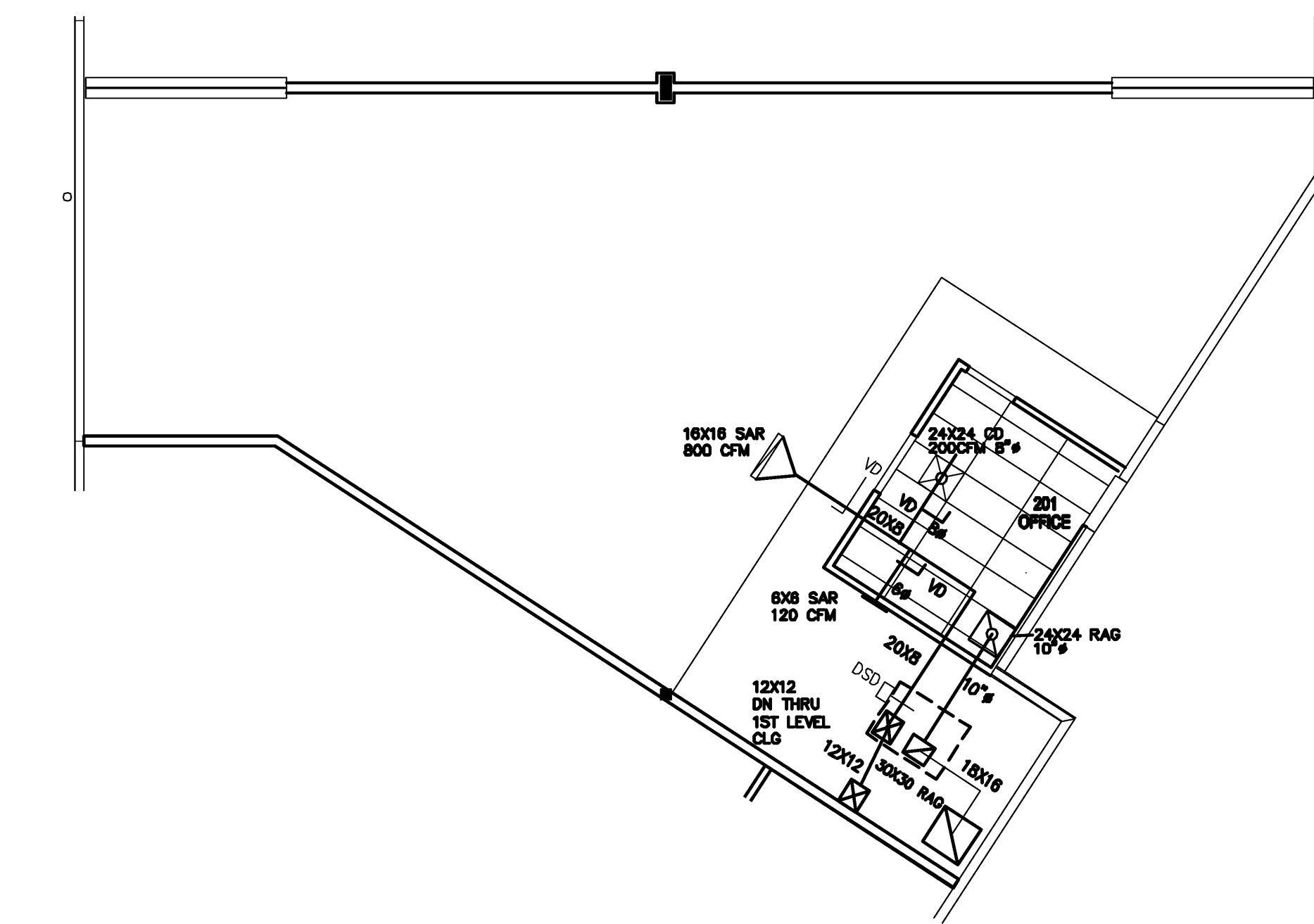

HIGH HVAC PLAN

SCALE: 1/8"=1'-0"

tercilla
courtemanche
 architects

AA 0008414
 2047 visa parkway, suite 100
 west palm beach, florida 33411 ph: 561.478.4457 fx: 561.478.4102

Tenant Improvement for:
Building B, Bay 10
 Southern Park of Commerce
 Palm Beach County, FL

commission 211059

date: 9-21-11

revision date

- no.
-
-
-
-
-
-
-

drawing M1.1

copyright 2011

THE CONTENTS OF THESE DOCUMENTS, INCLUSIVE OF THE DESIGN ARE COPYRIGHTED AND PROPRIETARY. THE ARCHITECT SHALL USE ALL REASONABLE MEANS TO PROTECT SAID COPYRIGHT. ANY USE NOT AUTHORIZED IN WRITING BY THE ARCHITECT IS PROHIBITED.

CHANE, INC.
 CONSULTING ENGINEERS
 2705 PARK STREET
 LAKE WORTH, FL 33460
 E-MAIL CHANEINC@AOL.COM
 TEL. 561-586-4003 FAX. 561-586-5688
 CERTIFICATE OF AUTHORIZATION #2559
 ARNOLD I. CHANE, PE #10024
 DAVID R. JONES, PE #41042
 HOWARD L. CHANE, PE #22467

ELECTRICAL NOTES

1. ELECTRICAL CONTRACTOR SHALL SUPPLY AND INSTALL ALL NEW ELECTRICAL WORK INDICATED. CONSTRUCTION SHALL BE IN ACCORDANCE WITH DRAWINGS AND APPLICABLE SPECIFICATIONS. IF A PROBLEM IS ENCOUNTERED IN COMPLYING WITH THIS REQUIREMENT, CONTRACTOR SHALL NOTIFY THE OWNER OR HIS REPRESENTATIVE AS SOON AS POSSIBLE AFTER DISCOVERY OF THE PROBLEM AND SHALL NOT PROCEED WITH THAT PORTION OF THE WORK UNTIL OWNER HAS DIRECTED CORRECTIVE ACTION TO BE TAKEN.
2. ELECTRICAL CONTRACTOR SHALL VISIT JOB SITE AND FAMILIARIZE HIMSELF WITH ALL CONDITIONS AFFECTING ELECTRICAL AND TELEPHONE INSTALLATION AND MAKE PROVISIONS AS TO THE COST THEREOF.
3. ALL WORK SHALL BE PERFORMED IN ACCORDANCE WITH THE NATIONAL ELECTRIC CODE AND THE FLORIDA BUILDING CODE.
4. DO NOT SCALE THE ELECTRICAL DRAWINGS. REFER TO ARCHITECTURAL PLANS AND ELEVATIONS FOR EXACT LOCATION OF ALL EQUIPMENT. CONFIRM WITH OWNERS REPRESENTATIVE.
5. MINIMUM WIRE SIZE SHALL BE #12 A.W.G. EXCLUDING CONTROL WIRING. UNLESS OTHERWISE NOTED, ALL CONDUCTORS SHALL BE COPPER WITH THHN INSULATION.
6. OUTLET BOXES SHALL BE PRESSED STEEL, IN DRY LOCATIONS, CAST ALLOY WITH THREADED HOLES IN WET OR DAMP LOCATIONS AND SPECIAL ENCLOSURES FOR OTHER CLASSIFIED AREAS.
7. CONTRACTOR SHALL GUARANTEE ALL MATERIALS AND WORKMANSHIP FREE FROM DEFECTS FROM A PERIOD OF NOT LESS THAN ONE YEAR FROM DATE OF ACCEPTANCE.
8. CORRECTION OF ANY DEFECTS SHALL BE COMPLETED WITHOUT ADDITIONAL CHARGE AND SHALL INCLUDE REPLACEMENT OR REPAIR OF ANY OTHER PHASE OF THE INSTALLATION WHICH MAY HAVE BEEN DAMAGED THERE BY.
9. ALL REQUIRED INSURANCE SHALL BE PROVIDED FOR PROTECTION AGAINST PUBLIC LIABILITY AND PROPERTY DAMAGE FOR THE DURATION OF THE PROJECT.
10. CONTRACTOR SHALL PAY FOR ALL PERMITS, FEES, INSPECTIONS AND TESTING. CONTRACTOR TO OBTAIN PERMIT AND APPROVED SUBMITTALS PRIOR TO BEGINNING WORK OR ORDERING EQUIPMENT.
11. THE ELECTRICAL INSTALLATION SHALL MEET ALL REQUIREMENTS OF POWER AND TELEPHONE COMPANIES.
12. CONTRACTOR SHALL COORDINATE WITH MECHANICAL DRAWINGS AND PROVIDE ALL NECESSARY CONTROL WIRING.
13. ALL CIRCUIT BREAKERS FEEDING MECHANICAL EQUIPMENT SHALL BE HACR TYPE CIRCUIT BREAKERS OR FUSED SWITCHES AS INDICATED.
14. PROVIDE AND INSTALL CONDUIT, CONDUCTORS, PULL WIRES, BOXES, COVER PLATES, DEVICES FOR ALL OUTLETS AS INDICATED.
15. CONTRACTOR SHALL BE RESPONSIBLE FOR ALL CUTTING AND PATCHING REQUIRED OF HIS WORK.
16. ELECTRICAL CONTRACTOR SHALL LABEL EXTERIOR OF ALL PANELS AND PROVIDE COMPLETE TYPEWRITTEN DIRECTORIES.
17. ALL ELECTRICAL AND TELEPHONE/ DATA OUTLETS TO BE AT 18" AFF UNLESS NOTED OTHERWISE, VERTICALLY MOUNTED.
18. ALL LIGHT SWITCHES TO BE AT 42" AFF.
19. LAY IN LIGHT FIXTURES TO BE SUPPORTED AT ALL FOUR CORNERS AND SECURED TO STRUCTURE ABOVE.
20. ALL ELECTRICAL WIRING SHALL BE THE RESPONSIBILITY OF THE ELECTRICAL CONTRACTOR. ALL ELECTRICAL WIRING FOR HVAC SYSTEM INCLUDING CONTROLS, THERMOSTATS, POWER, ETC. SHALL BE THE RESPONSIBILITY OF THE ELECTRICAL CONTRACTOR.
21. PANELBOARDS: ALL CURRENT CARRYING BUSES SHALL BE COPPER. ALL GROUND BUS BARS SHALL BE COPPER. PANELBOARD ENCLOSURES SHALL BE FURNISHED WITHOUT PRE-PUNCHED CONCENTRIC HOLES. IAC RATINGS SHALL BE AS INDICATED ON PANELBOARD SCHEDULES.
22. DISCONNECT SWITCHES SHALL BE H.P. RATED, HEAVY DUTY, ENCLOSURES AS REQUIRED BY EXPOSURE.
23. CONTRACTOR SHALL CONFIRM WITH FPL ANY AND ALL REQUIREMENTS SUCH AS: LUG SIZE RESTRICTIONS, CONDUIT ENTRY, TRANSFORMER SIZE, SCHEDULED DOWN TIME FOR OWNERS CONVICTION, ETC. ANY CONFLICTS SHALL BE BROUGHT TO ATTENTION OF THE ENGINEER BEFORE PROCEEDING WITH ANY WORK.
24. ALL SERVICE CONDUIT AND ALL EXPOSED EXTERIOR CONDUITS SHALL BE RIGID METAL. INTERIOR LIGHTING AND RECEPTACLE CONDUIT SHALL BE EMT. TYPE AC ARMORED CABLE SHALL BE AN ACCEPTABLE ALTERNATE FOR INTERIOR LIGHTING & RECEPTACLE CIRCUITS WHERE ALLOWED PER NEC ARTICLE 320.

SPECIFIC ELECTRICAL NOTES

1. WITHIN 30 DAYS AFTER THE DATE OF SYSTEM ACCEPTANCE, RECORD DRAWINGS OF THE ACTUAL INSTALLATION SHALL BE PROVIDED TO THE BUILDING OWNER, INCLUDING THE FOLLOWING:
 - A. A SINGLE LINE DIAGRAM OF THE BUILDING ELECTRICAL SYSTEM.
 - B. FLOOR PLANS INDICATING THE LOCATION & THE AREA SERVED FOR ALL DISTRIBUTION.
2. THE CONTRACTOR SHALL PROVIDE THE BUILDING OWNER W/AN OPERATING MANUAL & A MAINTENANCE MANUAL. THE MANUALS SHALL INCLUDE THE FOLLOWING:
 - A. SUBMITTAL DATA STATING EQUIPMENT RATINGS & SELECTED OPTIONS FOR EACH PIECE OF EQUIPMENT REQUIRING MAINTENANCE.
 - B. OPERATION MANUALS & MAINTENANCE MANUALS FOR EACH PIECE OF EQUIPMENT REQUIRING MAINTENANCE. REQUIRED ROUTINE MAINTENANCE ACTIONS SHALL BE CLEARLY IDENTIFIED.
 - C. NAMES & ADDRESSES OF AT LEAST ONE QUALIFIED SERVICE AGENCY.
3. PER CHAPTER 13, SECTION 413.1.ABC.1 THE VOLTAGE DROP FOR THE SERVICE CONDUCTORS DOES NOT EXCEED 2% & THE VOLTAGE DROP FOR THE BRANCH CIRCUIT CONDUCTORS DOES NOT EXCEED 3%.

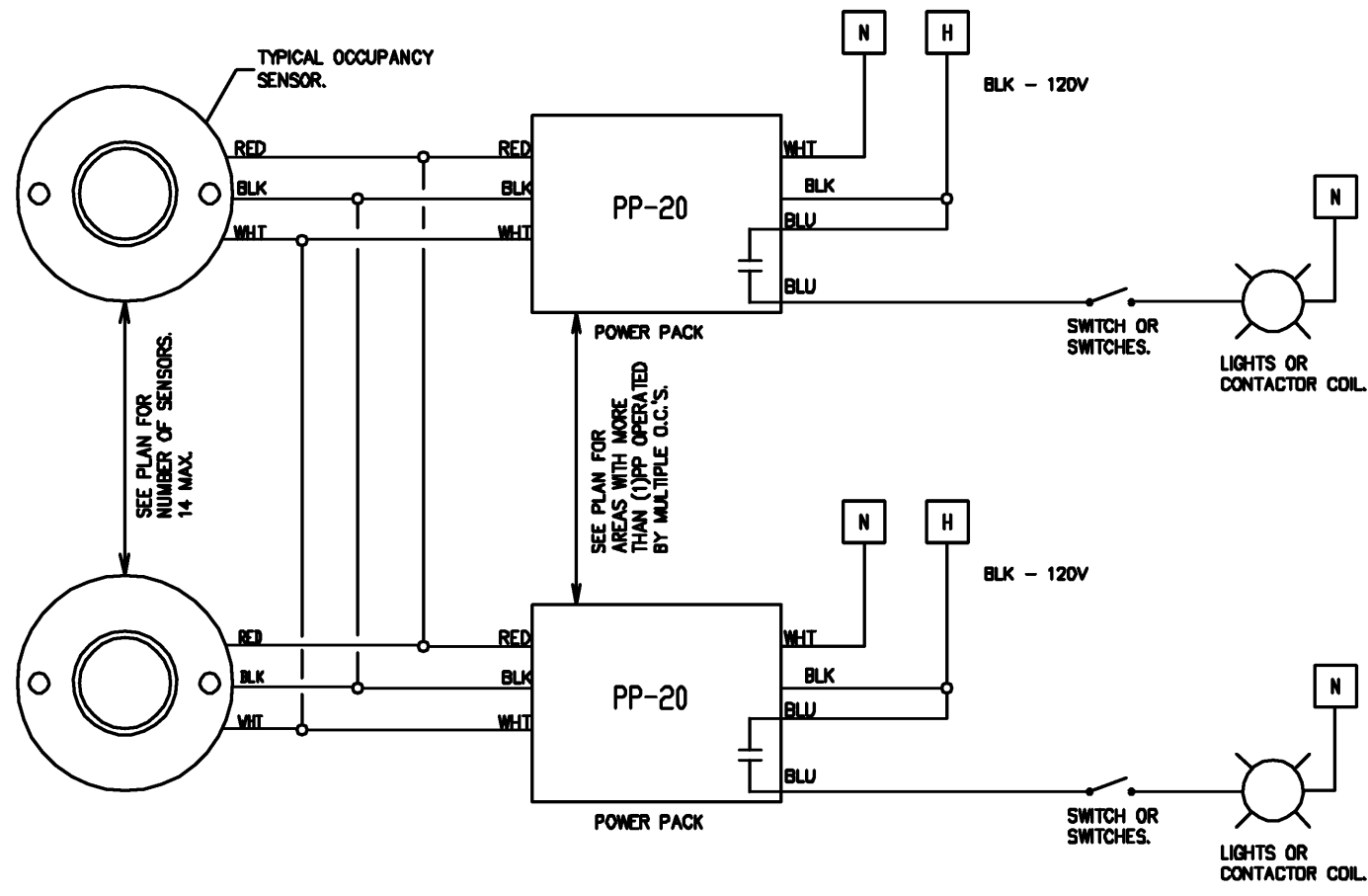

LOW VOLTAGE SENSOR(S) WIRING DIAGRAM NTS

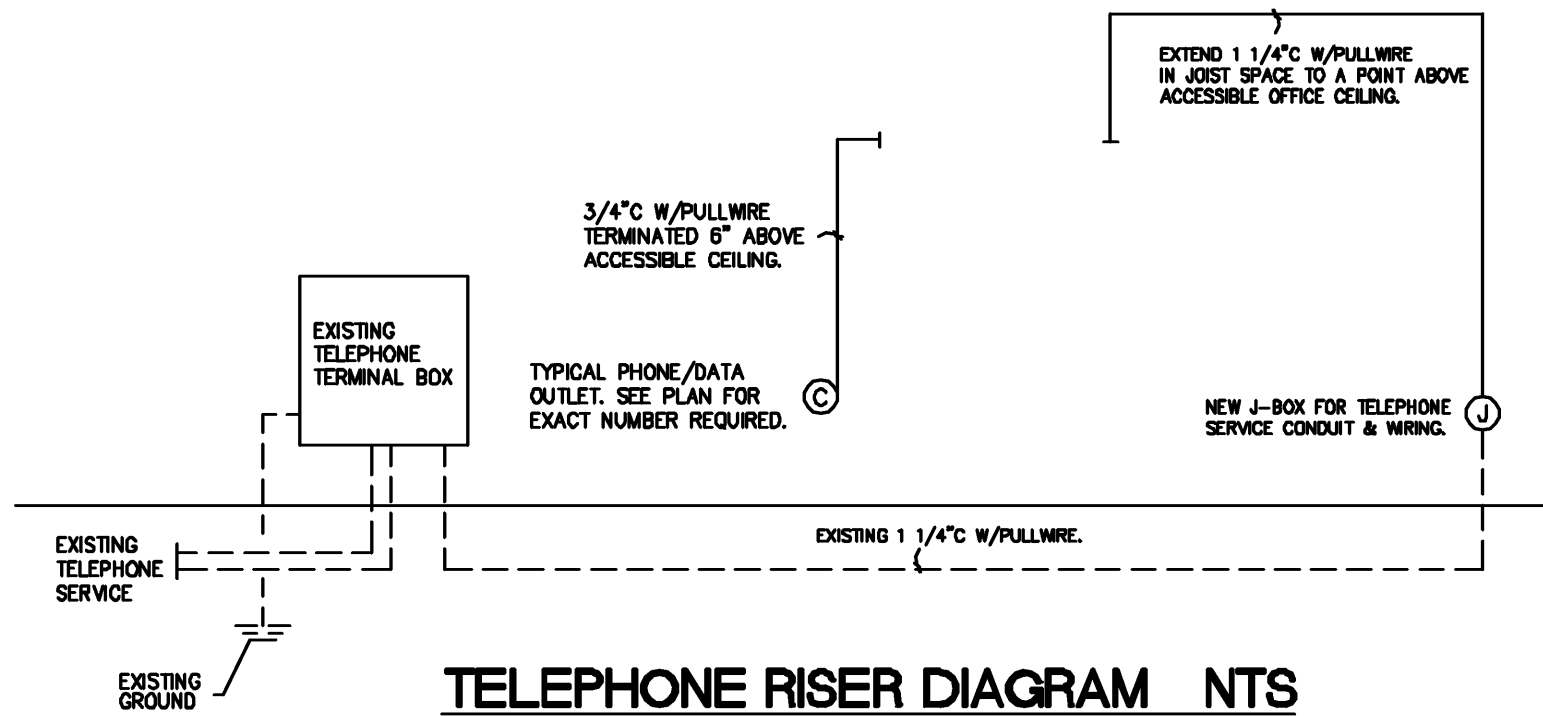

TELEPHONE RISER DIAGRAM NTS

| LOAD CENTER SCHEDULE 'N' | | | | | | | | | | | | |
|--------------------------|--------|-------------------|--------|-----------|------------------------------|-------------------------|----------|-----------------|---------------|-------------|--------------|------------------------|
| 120/208 | PHASES | 3 | PHASES | 4 | WIRES | 200 | AMPS PER | 42 | BIANCHI PANEL | X | NEUTRAL | |
| SURFACE MOUNTING | | 200 AMP MAIN LUGS | | | | SHORT CIRCUIT I= 22,000 | | | | AMP-SYM-RHS | | |
| COND. & WIRE | AMPS | A | B | C | LOAD | 3BR | C | 3 | 3 | AMPS | COND. & WIRE | |
| 1/2" #12 | 13 | | | | LIGHTING WAREHOUSE | 1 | 20 | 1 | 2 | 1 | 20 | RECEPTABLES UNDER MEZZ |
| 1/2" #10 | 3 | | | | MEZZANINE | 1 | 3 | 4 | | | 5 | WAREHOUSE |
| 1/2" #12 | 6 | | | | UNDER MEZZANINE | 1 | 5 | 6 | | | 8 | MEZZANINE |
| 1/2" #10 | 3 | | | | ROOF RECEPTACLE | 1 | 20 | 7 | 8 | | 3 | 1/2" #10 |
| 3/4" #8 | 28.4 | | | | ROOFTOP A/C | 3 | 50 | 9 | 10 | | 5 | 1/2" #12 |
| | 28.4 | | | | | 1 | 31 | 12 | 11 | | 3 | |
| | 28.4 | | | | | 1 | 39 | 14 | | | | |
| 3/4" #8 | 28.5 | | | | ELEC. WATER HEATER | 2 | 40 | 25 | 18 | | | |
| | 28.5 | | | | 5.5 KW | 1 | 17 | | | | | |
| 1/2" #12 | 8 | | | | 4 CEILING FANS & 4 DISCO LTS | 1 | 20 | 39 | 20 | | | |
| | | | | | SPACE | | | 21 | 22 | | | |
| | | | | | | | | 23 | 24 | | | |
| | | | | | | | | 25 | 26 | | | |
| | | | | | | | | 27 | 28 | | | |
| | | | | | | | | 29 | 30 | | | |
| | | | | | | | | 31 | 32 | | | |
| | | | | | | | | 33 | 34 | | | |
| | | | | | | | | 35 | 36 | | | |
| | | | | | | | | 37 | 38 | | | |
| | | | | | | | | 39 | 40 | | | |
| | | | | | | | | 41 | 42 | | | |
| TOTAL AMPS | | BUS A= 65 | | BUS B= 53 | | BUS C= 55 | | CONNECTED KVVA= | | | | |

LIGHTING FIXTURE SCHEDULE

| TYPE | MANUFACTURER | CATALOG NO. | LAMPS | REMARKS |
|------|--------------|----------------------------|-----------|---|
| A | DAYBRITE | 1FD232-PP-120-1/4-EB | (4)F32 T8 | 8 FT INDUSTRIAL FLUORESCENT. MOUNT LEVEL WITH BOTTOM OF JOIST. |
| B | DAYBRITE | 1FD232-PP-120-1/4-EB-GUARD | (4)F32 T8 | 8 FT INDUSTRIAL FLUORESCENT. PROVIDE WITH WIRE GUARD. MOUNT LEVEL WITH BOTTOM OF JOIST. |
| C | DAYBRITE | 11FD232-01-120-1/2-EB | (2)F32 T8 | 1/4" RECESSED TROFFER, PRISMATIC ACRYLIC LENS, FLANGE CEILING MOUNT. |
| D | DAYBRITE | 21GB332-01-120-1/2-EB | (3)F32 T8 | 2/4" RECESSED TROFFER, PRISMATIC ACRYLIC LENS. |
| X | CHLORIDE | E-R-B-1-120/6 | INCLUDED | LED SINGLE FACE EXIT WITH BATTERY. |
| Y | CHLORIDE | GM1 | INCLUDED | WALL MOUNTED EMERGENCY LIGHT WITH BATTERY. |

OCCUPANCY SENSOR DEVICE SCHEDULE

- MANUFACTURED BY SENSOR SWITCH.
- WALL SWITCH W/OCCUPANCY SENSOR & BUILT IN POWER PACK SENSOR SWITCH #NSD-PDT-WHITE
- HIGH BAY OCCUPANCY SENSOR TO CONTROL THE POWER PACK SENSOR SWITCH #JM-S-PDT(WHITE).
- 20 AMP POWER PACK THAT IS CONTROLLED BY THE OCCUPANCY SENSOR(S). LOCATE ABOVE ACCESSIBLE CEILING WIRE AHEAD OF ANY LOCAL SWITCHING. 14 SENSORS MAX. PER PP. SENSOR SWITCH #PP-20.
- LOW CEILING MOUNTED OCCUPANCY SENSOR TO CONTROL THE POWER PACK SENSOR SWITCH #JM-S-PDT(WHITE).

LIGHTING POWER CALCULATION

| SPACE | AREA (SQFT) | LPD (W/SQFT) | ALLOWABLE (W) | DESIGN (W) |
|---------------------|-------------|--------------|---------------|------------|
| UNDER MEZZANINE WH | 450 | 1.4 | 630 | 384 |
| MEZZANINE-STORAGE N | 450 | 0.9 | 405 | 384 |
| TOILETS | 102 | 0.9 | 46 | 64 |
| WAREHOUSE | 1710 | 1.4 | 2394 | 1536 |
| OFFICE-MEZZANINE | 450 | 1.1 | 495 | 448 |
| TOTAL | 2914 | | 6515 | 4800 |

THE DESIGN WATTAGE OF 4736 W IS LESS THAN THE ALLOWABLE WATTAGE OF 6515 W. LIGHTING POWER CALCULATION AS PER FBC 13-415.B.1 (SPACE BY SPACE METHOD)

ELECTRICAL LEGEND:

- RECESSED FLUORESCENT.
- 8 FT STEM-MOUNTED FLUORESCENT.
- EXIT LIGHT.
- EMERGENCY LIGHT.
- LIGHT FIXTURE TYPE DESIGNATION.
- DUPLEX RECEPTACLE.
- QUAD-PLEX RECEPTACLE.
- JUNCTION BOX 4" SQUARE UNLESS NOTED.
- DATA OUTLET.
- TELEVISION OUTLET.
- TELEPHONE OUTLET.
- WEATHERPROOF.
- GROUND FAULT INTERRUPTER.
- TOGGLE TYPE WALL SWITCH (3 - 3 WAY)
- TWO POLE RECEPTACLE.
- OCCUPANCY SENSOR (SEE DEVICE SCHEDULE).
- POWER PACK (SEE DEVICE SCHEDULE).
- EXHAUST FAN.
- DISCONNECT.
- DUCT SMOKE DETECTOR.
- TEST/RESET STATION.

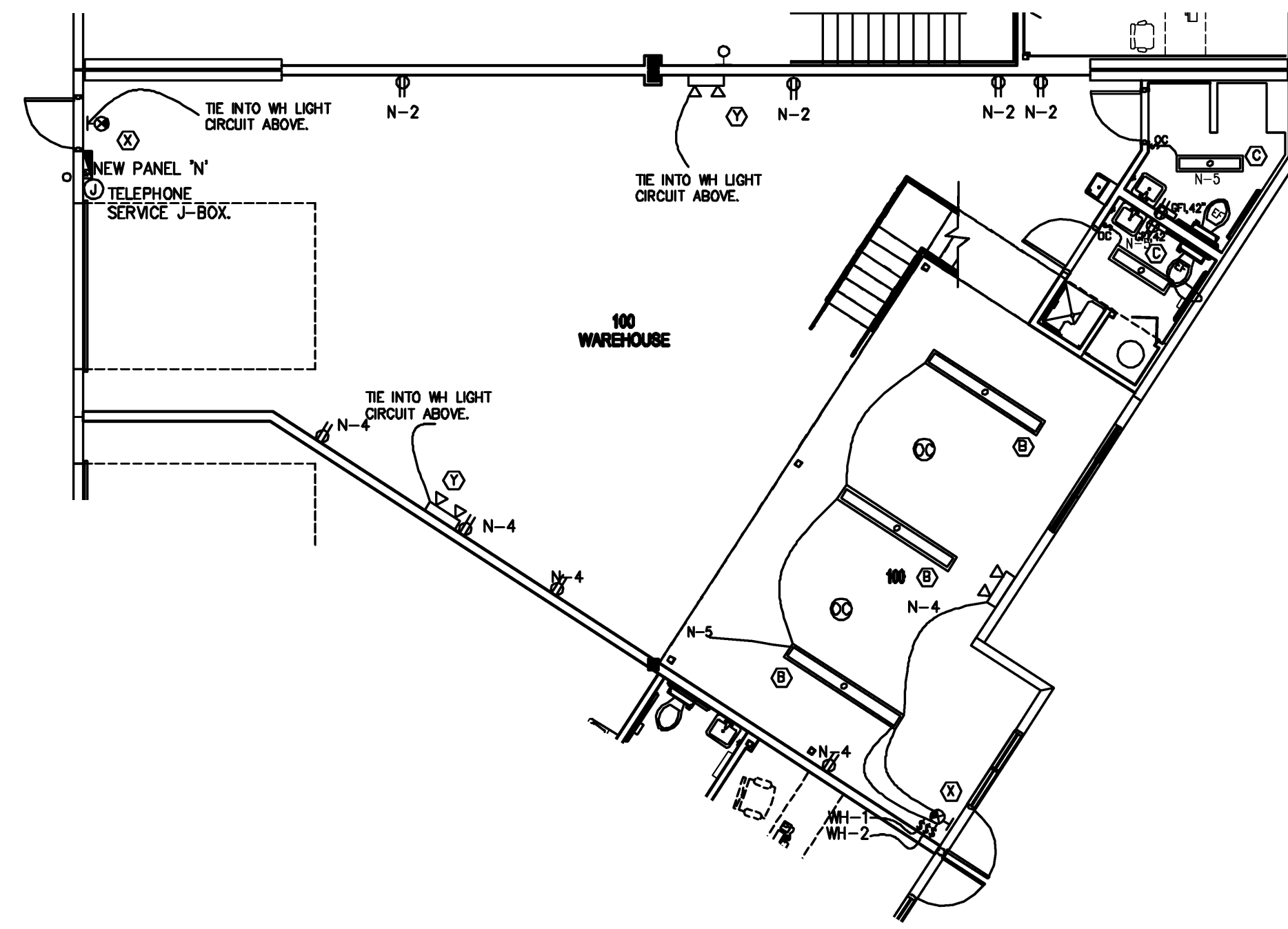

LOW POWER & LIGHTING PLAN

SCALE: 1/8"=1'-0"

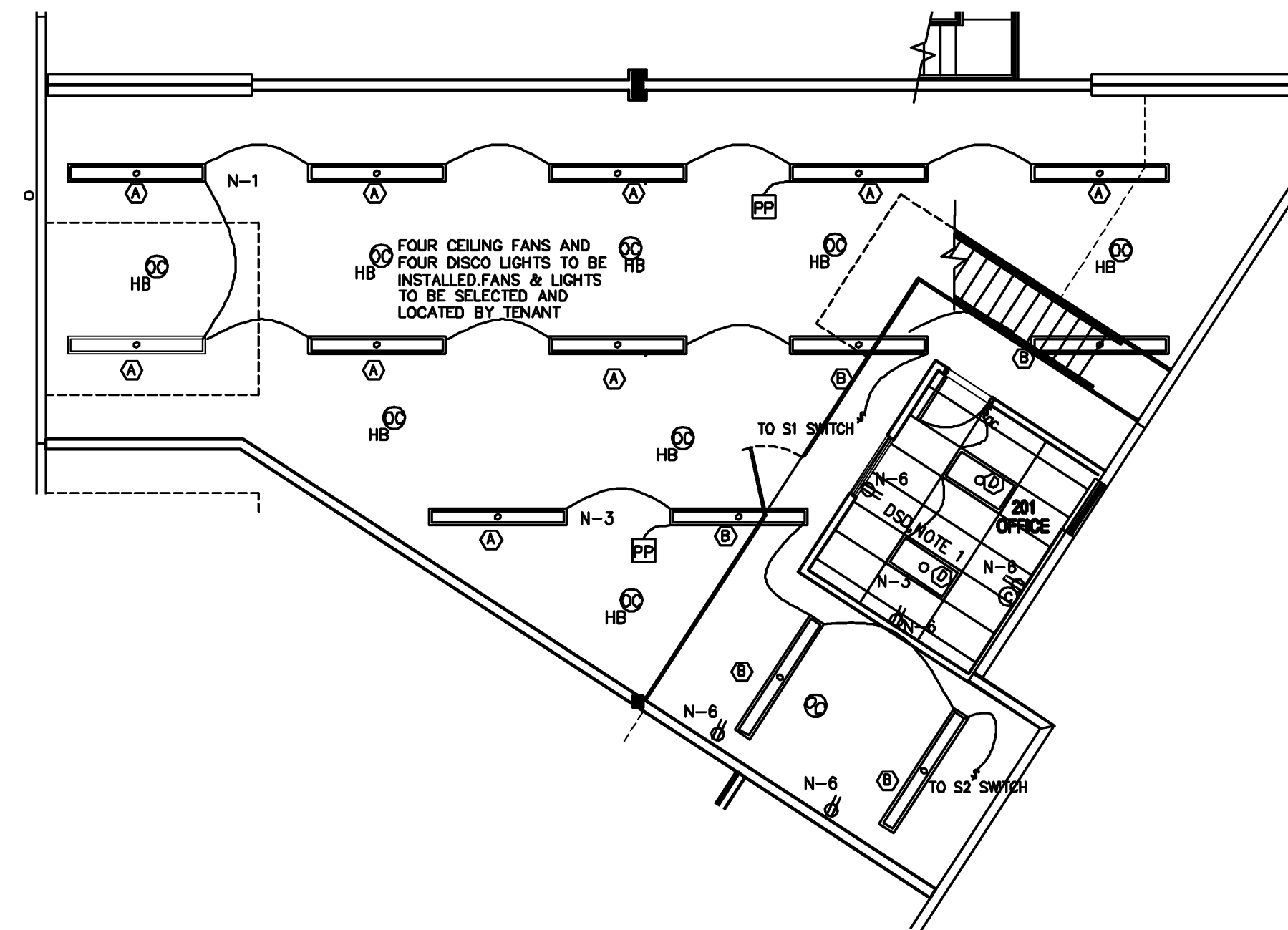

HIGH POWER & LIGHTING PLAN

SCALE: 1/8"=1'-0"

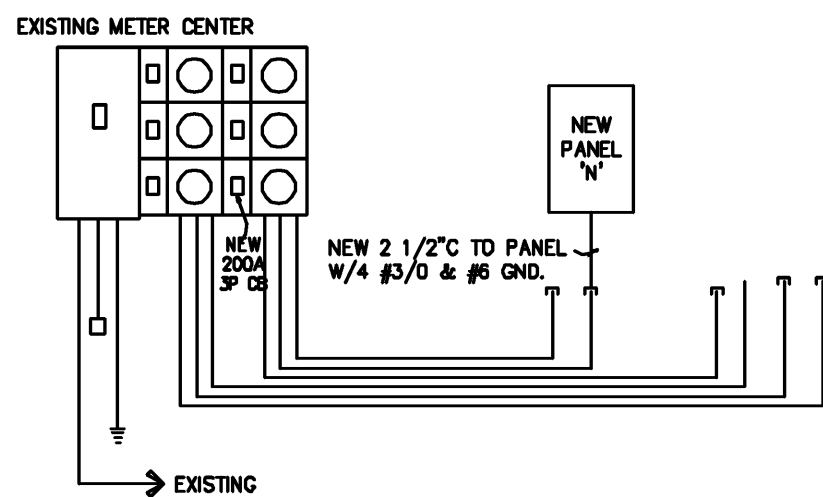

ELECTRICAL RISER DIAGRAM NTS

tercilla courtmanche architects

AA 0009414
2047 vista parkway, suite 100
west palm beach, florida 33411 ph: 561.478.4457 fx: 561.478.4102

Tenant Improvement for:
Building B, Bay 10
Southern Park of Commerce
Palm Beach County, FL

commission 211059

date: 9-21-11

revision date

no.

drawing

E1.1

copyright 2011

CHANE, INC.
CONSULTING ENGINEERS
2705 PARK STREET
LAKE WORTH, FL 33460
E-MAIL CHANEINC@AOL.COM
TEL. 561-586-4003 FAX. 561-586-5688
CERTIFICATE OF AUTHORIZATION #2559
ARNOLD I. CHANE, PE #10024
DAVID R. JONES, PE #41042
HOWARD L. CHANE, PE #22467