

SECTION A-A
1/8" = 1'-0"

PRIOR TO SUBMITTING HIS BID, THE CONTRACTOR SHALL FIELD VERIFY ALL EXISTING CONDITIONS AND INFORM THE ARCHITECT AND THE ENGINEER OF ANY DISCREPANCY BETWEEN THESE DOCUMENTS AND THE EXISTING CONDITIONS AND THE ENGINEER SHALL INCLUDE IN HIS BID TO CORRECT THE SAME AS SHOWN ON THESE DOCUMENTS. THE CONTRACTOR SHALL BE RESPONSIBLE FOR VERIFYING ALL EXISTING CONDITIONS AND DISCREPANCIES. THE CONTRACTOR SHALL BE RESPONSIBLE FOR VERIFYING ALL EXISTING CONDITIONS AND DISCREPANCIES. THE CONTRACTOR SHALL BE RESPONSIBLE FOR VERIFYING ALL EXISTING CONDITIONS AND DISCREPANCIES. NO CHANGES SHALL BE MADE TO THESE PLANS WITHOUT PRIOR APPROVAL FROM THE ENGINEER OF RECORD. ALL CHANGES SHALL BE SUBMITTED FOR REVIEW PRIOR TO INSTALLATION. NOT FOR BID UNTIL PERMIT HAS BEEN ISSUED.

PERMIT SET: 12/30/10

FRIB
CONSULTING

1640 N.W. BOCA RATON BLVD.
BOCA RATON, FL 33432
TEL: 561-391-1998
FAX: 561-391-1999
HAROLD R. TOBIAS, P.E. LICENSE #19315
E-MAIL: INFO@FRIBCONSULTING.COM

MECHANICAL PLAN

SCALE: 1/8" = 1'-0"

0 4' 8' 16' 32'

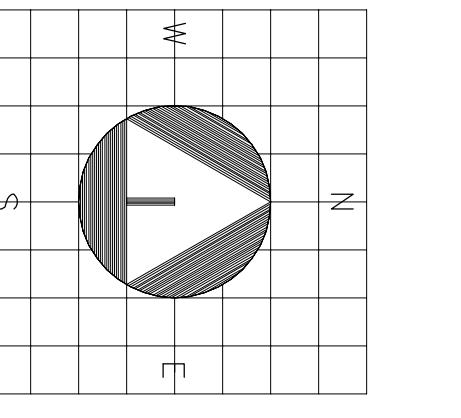

M1.01

sheet title: MECHANICAL PLAN file name: 10306_M1.01(2).DWG	revisions:
project no: 10306 date: 12/30/10 drawn by: AN/DC/AB checked by: MW	

DESIGNED BY: [Signature]
CHECKED BY: [Signature]
DATE: 12/30/10
SCALE: 1/8" = 1'-0"
ALL RIGHTS RESERVED

TENANT IMPROVEMENTS FOR:
West Marine
Shoppes at City Centre (North Palm Marketplace)
11241 U.S. HIGHWAY ONE
NORTH PALM BEACH, FLORIDA

GS&P GLIDDEN • SPINA & PARTNERS
ARCHITECTURE • INTERIOR DESIGN, INC.

PHONE: 561.684.6844 • FAX: 561.684.5594 • E-MAIL: info@gsp-architects.com
1401 FORUM WAY, SUITE 100 • WEST PALM BEACH, FLORIDA 33401
FL License: #AA26001602

Keith M. Spina #AR13419 Benjamin John Glidden, III #AR6536