

Model: CUE-101HP-VG

Direct Drive Upblast Centrifugal Roof Exhaust Fan

Dimensional	
Quantity	1
Weight w/o Acc's (lb)	61
Weight w/ Acc's (lb)	104
Optional Damper (in.)	12 x 12
Roof Opening (in.)	14.5 x 14.5

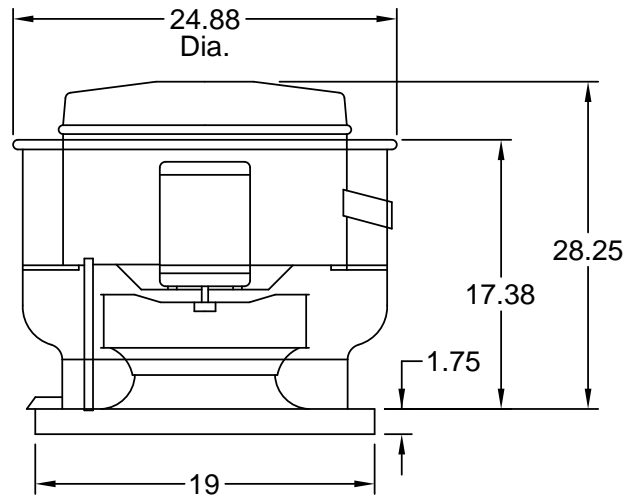

Reference assembly view drawings for actual dimensions with mounted accessories

Performance	
Requested Volume (CFM)	310
Actual Volume (CFM)	310
External SP (in. wg)	1.8
Total SP (in. wg)	1.8
Fan RPM	2207
Operating Power (hp)	0.28
Elevation (ft)	20
Airstream Temp.(F)	70
Air Density (ft3)	0.075
Tip Speed (ft/min)	6,429
Static Eff. (%)	32

Motor	
Motor Mounted	Yes
Size (hp)	1/2
V/C/P	115/60/1
Enclosure	ODP
Motor RPM	2500
Windings	1
FLA (Amps)	6.5

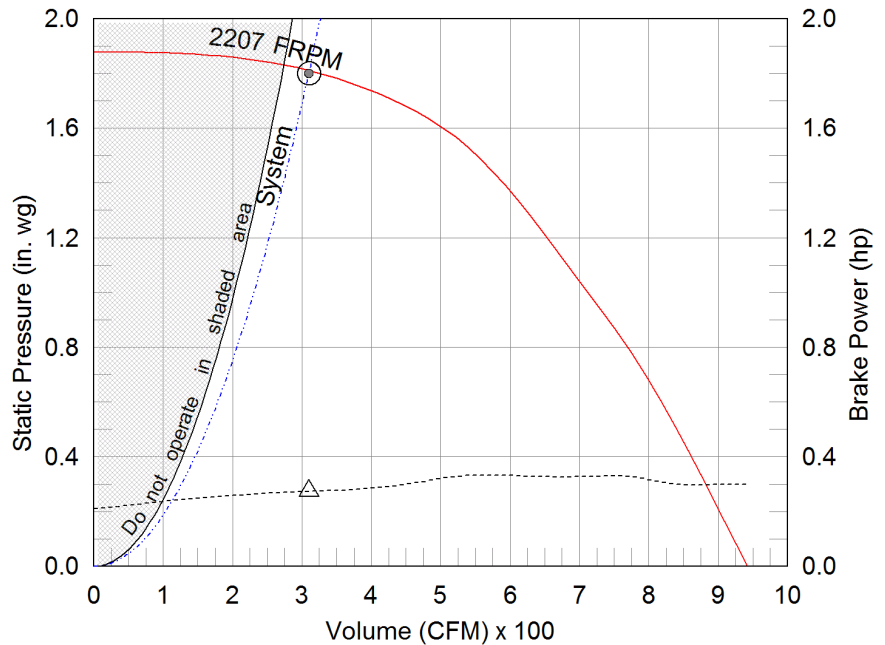

- △ Operating Bhp point
- Operating point at Total SP
- Operating point at External SP
- Fan curve
- - - System curve
- - - Brake horsepower curve

Sound Power by Octave Band

Sound Data	62.5	125	250	500	1000	2000	4000	8000	LwA	dBA	Sones
Inlet	80	79	72	68	66	63	58	56	72	61	11.2

Notes:

All dimensions shown are in units of in..
*FLA - based on tables 150 or 148 of National Electrical Code 2002. Actual motor FLA may vary, for sizing thermal overload, consult factory.
LwA - A weighted sound power level, based on ANSI S1.4
dBA - A weighed sound pressure level, based on 11.5 dB attenuation per Octave band at 5.0 ft - dBA levels are not licensed by AMCA International
Sones - calculated using AMCA 301 at 5.0 ft



Model: CUE-101HP-VG

Direct Drive Upblast Centrifugal Roof Exhaust Fan

Standard Construction Features:

- Aluminum housing - Backward inclined aluminum wheel - Aluminum curb cap with prepunched mounting holes - Drain trough - Ball bearing motors (sizes 98-160), sleeve bearing motors (sizes 60-95) - Motor isolated on shock mounts - Corrosion resistant fasteners

Options & Accessories:

Motor - Vari-Green EC motor w/Mounted Potentiometer Dial
UL/cUL 705 Listed - "Power Ventilators"
Switch, NEMA-1, Toggle, Junction Box Mounted & Wired
High Wind Rated
Florida Product Approval #FL13225.1 & Miami-Dade NOA #12-0120.13
Texas Department of Insurance Product Evaluation RV-73
Roof Curb, GPF-19-G18, Under Sized 1 in. Total
Damper, WD-100-PB-12X12, Gravity Operated (Loose), Not Coated
Birdscreen: Aluminum

Vari-Green

Motor & Control Options

An EC motor that uses AC input power and internally converts it to DC power. Potentiometer (dial) mounted on the motor enclosure adjusts the speed (RPM) down 80%.

Motor Type: Dial on Motor

Wiring Diagram

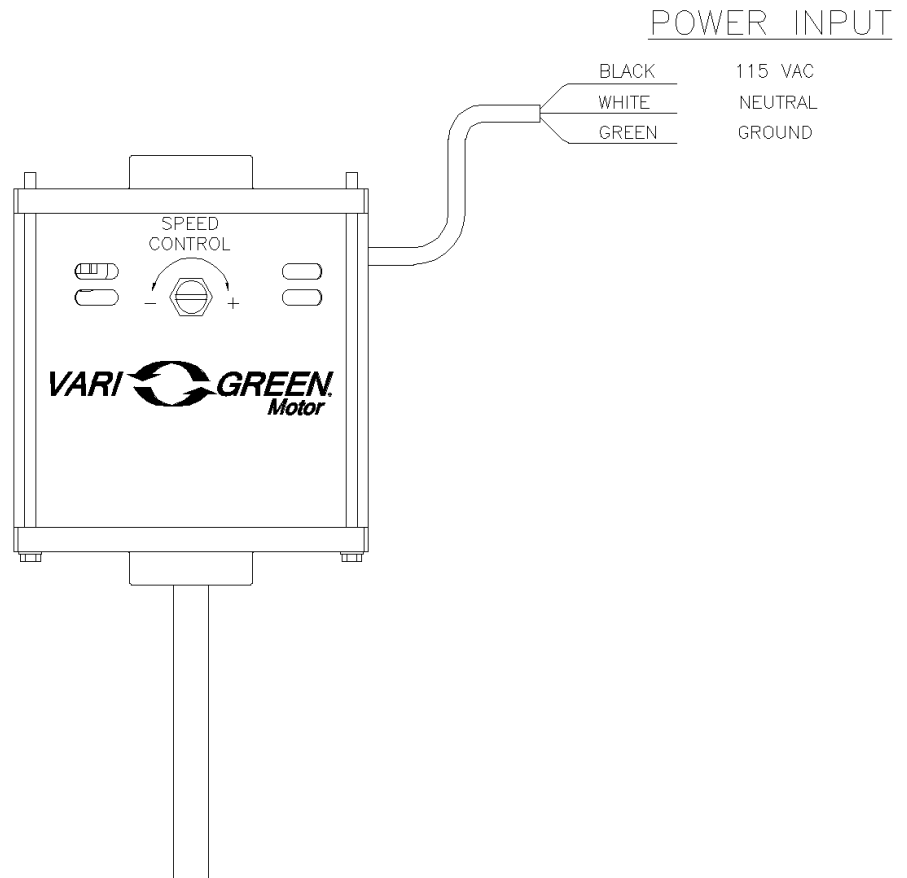

Horizontal Mount Exhaust Damper

Model: WD-100

Standard Construction Features:

- Model WD-100 is a horizontal mount exhaust damper (air flow up) and is constructed of 18 ga galvanized steel with pre-punched mounting holes - Damper blades are 0.025 in. roll formed aluminum with vinyl seals on the closing edge, and spring assisted for ease of opening - Steel axles are 0.188 in. diameter zinc plated mounted in acetal bushings - Synthetic axle bearings

Damper Configuration:

Actuator Type: Gravity

End Switch: No

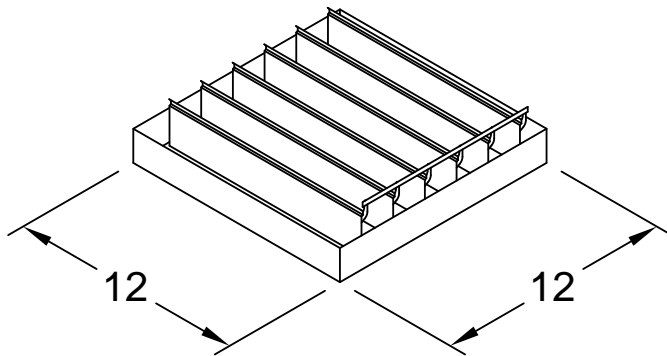

DAMPER

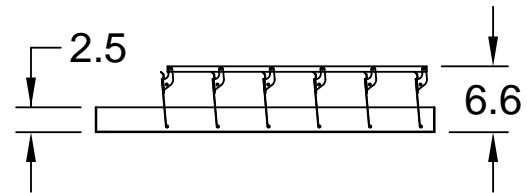

TYP. SECTION VIEW

Notes: All dimensions shown are in units of in.
Width And height furnished approximately 0.125 in. undersize

GPF Roof Curb

STANDARD CONSTRUCTION FEATURES

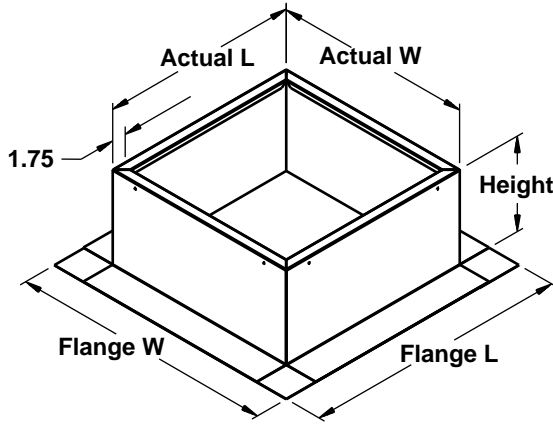

- Welded Aluminum (0.064 in.) or galvanized (18 ga) construction
 - Straight sided
 - 5 in. roof mounting / flashing flange
 - 1 in. 3 lb density insulation
- Roof Opening - The Maximum roof opening dimension should not be greater than the "Actual" top outside dimension minus 2 in.. With dampers, the Minimum roof opening dim. should be at least 2.5 in. more than the damper dim.

NOTES:

- * The Roof Opening Dim. may NOT be the Structural Opening Dim.
- * Tray - Damper Tray is optional and must be specified. Tray size is same as damper size.
- * Height - Available from 8 in. to 42 in. as specified in 0.5 in. increments.
- * Security Bars are optional & must be specified. Frames & gridwork are all 10 ga steel. Gridwork is welded to the frame & the frame is welded to the curb. To prevent corrosion, they are coated w/Greenheck's high...

NOTES: All dimensions shown are in units of inches

Mark	Qty.	Cap W x L	Actual W x L	Flange W x L	Height	Damper Tray W x L
UPBLAST FAN	1	19 x 19	18 x 18	28 x 28	18	